

Individual mounting

Valve only - No base non "plug-in" Conform to ISO 5599/1	Valve only - No base "plug-in" Conform to ISO 5599/2
--	--

Series

Manifold mounting

Valve only - No base non "plug-in" Conform to ISO 5599/1	Valve only - No base "plug-in" Conform to ISO 5599/2
--	--

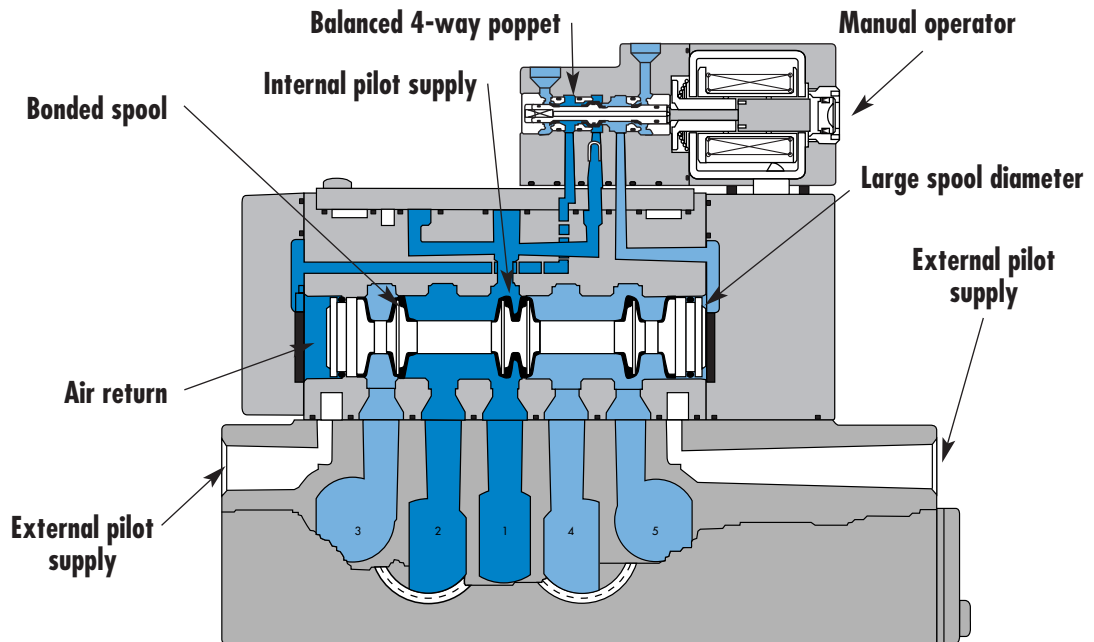

33
34
36
32
37
38
52
67
69
44
46
42
47
48P
48
400
92
93
ISO 01
ISO 02
ISO 1
ISO 2
ISO 3

SERIES FEATURES

- Plug-in (5599/2) and non plug-in (5599/1) models.
- 2-position, single or double operator. (Solenoid or Remote Air)
- 3-position, double solenoid, open center, closed center, and pressure center.
- Extended or recessed manual operators.
- Single pressure and dual pressure.
- Individual base or add-a-unit manifold base.
- Plug-in, sandwich, single and dual pressure regulators for both individual and manifold valves.

Function	Port size	Flow [Max]	Individual/Manifold mounting	Series
5/2, 5/3	1/4" - 3/8"	1.8 C_v	Valve only - No base non "plug-in" Conform to ISO 5599/1	

OPERATIONAL BENEFITS

1. Unique patented Macsolenoid® for fastest possible response times and virtually burn-out proof AC solenoid operation.
2. Balanced poppet 4-way pilot valve provides maximum shifting forces, precise repeatability and consistent operation.
3. MAC spool and bore combination wipes away contamination, eliminates sticking and allows for use on non-lube service.
4. Large spool area for maximum shifting forces even at minimum operating pressure.
5. Very high flow in a compact package.
6. Plug-in design of valves, bases and regulators for modular assembly and ease of maintenance.
7. Internal or external pilot operation. Manifolds supplied with common external pilot.
8. Air only return. Optional memory spring is also available.
9. Optional low wattage DC solenoid down to 1.0 watt.



33
34
36
32
37
38
52
67
69
44

HOW TO ORDER

SINGLE PRESSURE MODELS

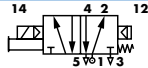
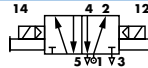
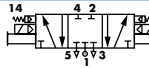
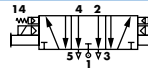
Pilot air	5/2 Single operator	5/2 Double operator	5/3 Closed center	5/3 Open center
Internal	 MV-B1A-AAAA-DM-Dxxx-xxx	 MV-B1A-ABAA-DM-Dxxx-xxx	 MV-B1A-AEAA-DM-Dxxx-xxx	 MV-B1A-AFAA-DM-Dxxx-xxx
External "12" end	MV-B1A-AAAB-DM-Dxxx-xxx	MV-B1A-ABAB-DM-Dxxx-xxx	MV-B1A-AEAB-DM-Dxxx-xxx	MV-B1A-AFAB-DM-Dxxx-xxx

46
42

DUAL PRESSURE MODELS

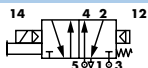
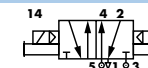
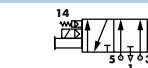
Pilot air	5/2 Single operator	5/2 Double operator	5/3 Pressure center
Internal pilot From port #3	 MV-B1A-ACAD-DM-Dxxx-xxx	 MV-B1A-ADAD-DM-Dxxx-xxx	 MV-B1A-AGAD-DM-Dxxx-xxx
Internal pilot From port #5	MV-B1A-ACAE-DM-Dxxx-xxx	MV-B1A-ADAE-DM-Dxxx-xxx	MV-B1A-AGAE-DM-Dxxx-xxx
External pilot From "12" end	MV-B1A-ACAB-DM-Dxxx-xxx	MV-B1A-ADAB-DM-Dxxx-xxx	MV-B1A-AGAB-DM-Dxxx-xxx

47
48P
48
400

SOLENOID OPERATOR ▶

DM-D XXX-XXX*

XX Voltage	X Lead wire length	X Manual operator	XX Electrical connection
JA 110/50, 120/60	A 18" (Flying leads)	1 Non-locking recessed	KA Square connector
JB 220/50, 240/60	B 24" (Flying leads)	2 Locking recessed	KD Square connector with light
JC 24/50, 24/60	J Connector		JB Rectangular connector
FB 24 VDC (1.8W)			JD Rectangular connector with light
DA 24 VDC (5.4W)			BA Flying leads
DF 24 VDC (12.7W)			

92

93
ISO 01
ISO 02

ISO 1

ISO 2

ISO 3

* Other options available, see page 309.
Note: ISO series, valve and base are ordered separately, see page 231 for base code.

OPTIONS

Valve function :

MV-B1A-**AXX**-XX-Dxxx-xxx

- J** for single operator universal spool (ext. pilot only)
- K** for double operator universal spool (ext. pilot only)

Pilot style :

MV-B1A-AXX-**DM**-Dxxx-xxx

- DM** Pilot exhaust muffled
- DP** Pilot exhaust piped (#10-32)

Spool return :

MV-B1A-AX**A**X-XX-Dxxx-xxx

- A** Standard return
- B** Memory spring return

TECHNICAL DATA

Fluid :	Compressed air, vacuum, inert gases
Pressure range :	Internal pilot : 20 to 120 PSI External pilot : vacuum to 120 PSI
Pilot pressure :	Single/double operator : 20 to 120 PSI, 3 positions : 30 to 120 PSI
Lubrication :	Not required, if used select a medium aniline point lubricant (between 180°F and 210°F)
Filtration :	40 µ
Temperature range :	0°F to 120°F (-18°C to +50°C)
Flow :	3/8": (1.8 C _v) – 1/4": (1.6 C _v)
Coil :	Class A continuous duty, #22 AWG x 18 leads
Voltage range :	-15% to +10% of nominal voltage
Protection :	Consult factory
Power :	~ Inrush 7.6 VA Holding: 4.8 VA = 1 to 12.7 W
Response times : (with 5,4 W coil)	Energize : 11.3 ms De-energize : 7.8 ms

- Options :
- Sandwich flow controls: FCP1A-BA (screwdriver slot adjustment)
FCP1A-BB (locking knob adjustment)
 - Sandwich regulator, see „Regulators’ section
- Spare parts :
- Pilot valve: DMB-Dxxx-xxx • Valve to base pressure seal: 16661

DIMENSIONS

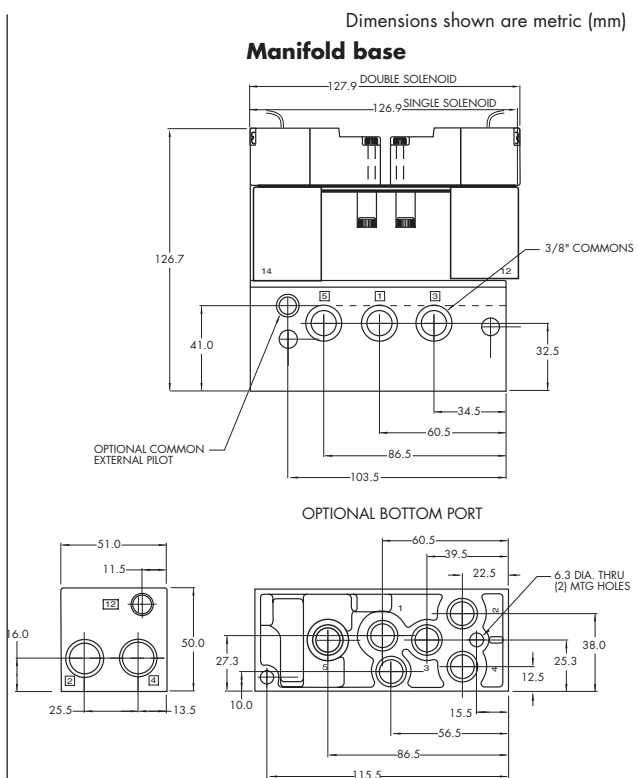
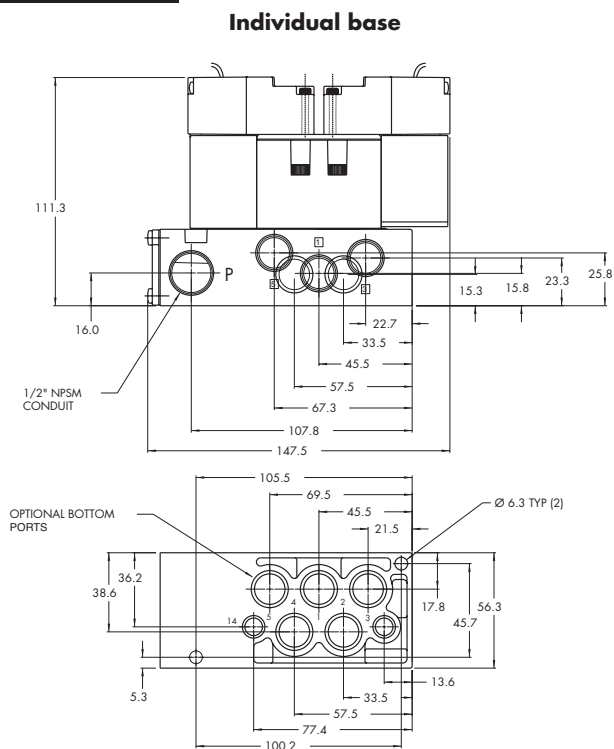

Function	Port size	Flow [Max]	Individual/Manifold mounting	Series
5/2, 5/3	1/4" - 3/8"	1.8 C_v	Valve only - No base "plug-in" Conform to ISO 5599/2	

OPERATIONAL BENEFITS

1. Unique patented Macsolenoid® for fastest possible response times and virtually burn-out proof AC solenoid operation.
2. Balanced poppet 4-way pilot valve provides maximum shifting forces, precise repeatability and consistent operation.
3. MAC spool and bore combination wipes away contamination, eliminates sticking and allows for use on non-lube service.
4. Large spool area for maximum shifting forces even at minimum operating pressure.
5. Very high flow in a compact package.
6. Plug-in design of valves, bases and regulators for modular assembly and ease of maintenance.
7. Internal or external pilot operation. Manifolds supplied with common external pilot.
8. Air only return. Optional memory spring is also available.
9. Optional low wattage DC solenoid down to 1.0 watt.



33
34
36
32
37
38
52
67
69
44

HOW TO ORDER

SINGLE PRESSURE MODELS

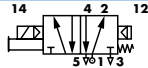
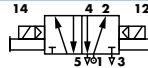
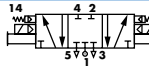
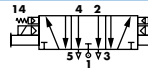
Pilot air	5/2 Single operator	5/2 Double operator	5/3 Closed center	5/3 Open center
Internal	 MV-P1A-AAAA-DM-DxxP-xxx	 MV-P1A-ABAA-DM-DxxP-xxx	 MV-P1A-AEAA-DM-DxxP-xxx	 MV-P1A-AFAA-DM-DxxP-xxx
External "12" end	MV-P1A-AAAB-DM-DxxP-xxx	MV-P1A-ABAB-DM-DxxP-xxx	MV-P1A-AEAB-DM-DxxP-xxx	MV-P1A-AFAB-DM-DxxP-xxx

46
42

DUAL PRESSURE MODELS

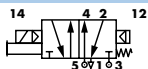
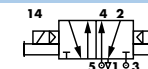
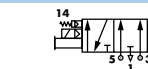
Pilot air	5/2 Single operator	5/2 Double operator	5/3 Pressure center
Internal pilot From port #3	 MV-P1A-ACAD-DM-DxxP-xxx	 MV-P1A-ADAD-DM-DxxP-xxx	 MV-P1A-AGAD-DM-DxxP-xxx
Internal pilot From port #5	MV-P1A-ACAE-DM-DxxP-xxx	MV-P1A-ADAE-DM-DxxP-xxx	MV-P1A-AGAE-DM-DxxP-xxx
External pilot From "12" end	MV-P1A-ACAB-DM-DxxP-xxx	MV-P1A-ADAB-DM-DxxP-xxx	MV-P1A-AGAB-DM-DxxP-xxx

47
48P
48
400

SOLENOID OPERATOR ▶

DM-D XX P-XXX*

XX Voltage	X Manual operator	XX Electrical connection
JA 110/50, 120/60 (2.9W)	1 Non-locking recessed	DM Plug-in
JB 220/50, 240/60 (2.9W)	2 Locking recessed	DN Plug-in with diode
JC 24/50, 24/60 (2.9W)		DP Plug-in with M.O.V.
FB 24 VDC (1.8W)		DG Plug-in with ground
DA 24 VDC (5.4W)		
DF 24 VDC (12.7W)		

92
93

* Other options available, see page 309.
Note: - ISO series, valve and base are ordered separately, see page 233 for base codes.
- Ground wire required for 30 volts or higher.

OPTIONS

Valve function :

MV-P1A-AXXX-XX-DxxP-xxx
J for single operator universal spool (ext. pilot only)
K for double operator universal spool (ext. pilot only)

Pilot style :

MV-P1A-AXXX-DM-DxxP-xxx
DM Pilot exhaust muffled
DP Pilot exhaust piped (#10-32)

Spool return :

MV-P1A-AXX-AX-XX-DxxP-xxx
A Standard return
B Memory spring return
D Standard return with light
E Memory spring return with light

ISO 01
ISO 02
ISO 1
ISO 2
ISO 3

TECHNICAL DATA

Fluid :	Compressed air, vacuum, inert gases
Pressure range :	Internal pilot: 20 to 120 PSI External pilot : vacuum to 120 PSI
Pilot pressure :	Single/double operator : 20 to 120 PSI, 3 positions : 30 to 120 PSI
Lubrication :	Not required, if used select a medium aniline point lubricant (between 180°F and 210°F)
Filtration :	40 µ
Temperature range :	0°F to 120°F (-18°C to +50°C)
Flow :	3/8": (1.8 C _v) – 1/4": (1.6 C _v)
Coil :	Class A continuous duty, #22 AWG x 12 base leads
Voltage range :	-15% to +10% of nominal voltage
Protection :	Consult factory
Power :	~ Inrush 7.6 VA Holding: 4.8 VA = 1 to 12.7 W
Response times : (with 5,4 W coil)	Energize : 10 ms De-energize : 9 ms

- Options :
- Sandwich flow controls: FCP1A-AA (screwdriver slot adjustment)
FCP1A-AB (locking knob adjustment)
 - Sandwich regulator, see „Regulators’ section
- Spare parts :
- Pilot valve: DMB-DxxP-xxx • Valve to base pressure seal: 16661

DIMENSIONS

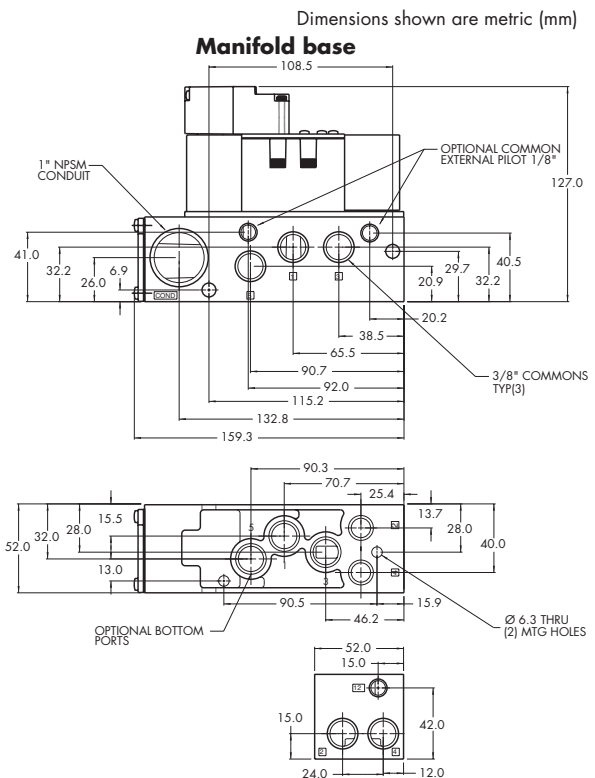
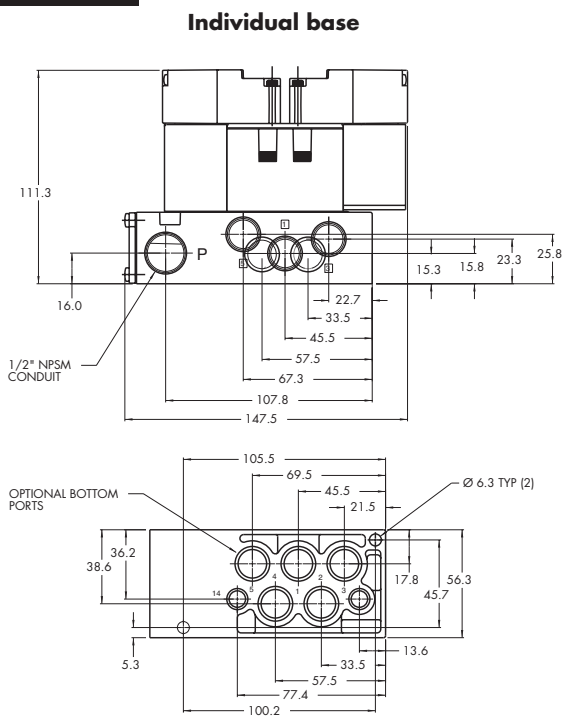



Codification table for voltages / Manual operator / Electrical connection

VALVE CODE > **-DM- D XX X-X XX**
1 2 3 4

OPTIONS AVAILABLE FOR

- Pilot operated valves 52, 67, 92, 93, 400, ISO1, ISO2, ISO3 Series

1. VOLTAGE

D-XX X-X XX	VOLTAGE
DA	24 VDC (5.4W)
DB	12 VDC (5.4W)
DC	12 VDC (7.5W)
DD	24 VDC (7.3W)
DE	12 VDC (12.7W)
DF	24 VDC (12.7W)
DK	110 VDC (4.7W)
DJ	28 VDC (5.2W)
DL	64 VDC (6.0W)
DM	36 VDC (5.3W)
DN	6 VDC (6.0W)
DR	90 VDC (6.6W)
DS	110 VDC (7.3W)
DT	75 VDC (5.6W)
DP	48 VDC (5.8W)
FA	12 VDC (1.8W)
FB	24 VDC (1.8W)
FE	12 VDC (2.4W)
FF	24 VDC (2.4W)
JA	120/60, 110/50 (2.9W)
JB	240/60, 220/50 (2.9W)
JC	24/60, 24/50 (3.7W)
JD	100/60, 100/50, 110/60 (3.9W)
JE	220/60 (3.4W)
JF	240/50 (2.8W)
JG	200/60, 200/50 (3.9W)

2. WIRE LENGTH

D-XX X-X XX	WIRE LENGTH
0	No wires
A	18"
B	24"
C	36"
D	48"
E	72"
F	96"

3. MANUAL OPERATOR

D-XX X-X XX	MANUAL OPERATOR
0	No operator
1	Non-locking recessed
2	Locking recessed
3	Non-locking extended
4	Locking extended

4. ELECTRICAL CONNECTION

D-XX X-X XX	ELECTRICAL CONNECTION
BA*	Flying leads (grommet)
BK*	BA with protection diode
BL*	BA with protection varistor
BM**	Flying leads (solenoid plug-in)
BN**	BM with protection diode
BP**	BM with protection varistor
BG**	BM with ground
BH**	BM with protection diode & ground
BJ**	BM with protection varistor & ground
CA*	1/2" NPS conduit with flying leads
CM*	1/2" NPS metal conduit with flying leads
CN*	1/2" NPS metal conduit with flying leads & ground
JB	Rectangular connector
JD	JB with light
JM	Rectangular connector (male only)
KA	Mini square connector
KB	KA with protection diode
KC	KA with protection varistor
KD	KA with light
KE	KA with light and protection diode
KF	KA with light and protection varistor
KG	KA with light & diode
KJ	Mini square connector (male only)
KK	KJ with protection diode (male only)
KL	KJ with protection varistor (male only)
TA	Dual tabs with receptacles
TB	TA with protection diode
TD	TA with light
TE	TA with light and protection diode
TJ	Dual tabs (male only)
TK	TJ with protection diode
TM	TJ with light
TN	TJ with light and protection diode

* From Lead wire length options choose A through F

** From Lead wire length options choose 0 through F

Note: When coil is above 30 volts, a ground wire is required. Applies to options with flying leads.

Individual mounting

valve only

Series

Manifold mounting

valve only

35

100

200

55

56

57

58

59

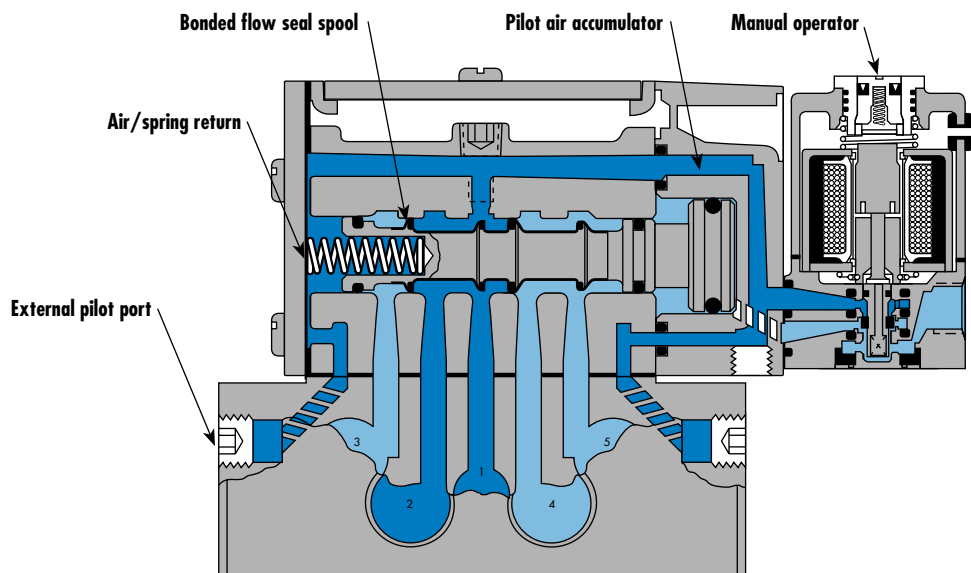

45

700

900

82

SERIES FEATURES

- Fastest available response time with patented MACSOLENOID®.
- No-stick operation is ensured by wiping action of unique MAC spool/bore combination.
- Balanced poppet pilot valve for high flow, precise repeatability, and consistent operation.
- Large spool piston for high shifting force even at minimum operating pressure
- Air/spring return for consistent shifting on single solenoid models.
- Patented virtually burn-out proof AC solenoid.
- Optional low wattage DC solenoids down to 1.0 watt.
- Various manual operators & electrical connectors are available.
- Muffled or threaded pilot exhaust ports.
- Internal of external pilot models available.

6300

6500

6600

1300

800

ISO 1

ISO 2

ISO 3

MAC 125A

MAC 250A

MAC 500A

VALVE CONFIGURATIONS AVAILABLE

- 2-Pos., single or double operators (solenoid or remote air).
- Single or dual pressure.
- 3-Pos., double operator-closed center, open center or pressure center (solenoid or remote air).
- Individual base or add-a-unit manifold base.
- Internal pilot or external pilot (including a common external pilot or manifold models).
- Side porting and bottom porting options.

*International Standards Organization ISO Common Base Interface (ISO Std. 5599/1)

SPECIAL APPLICATION INSTRUCTIONS :

On all models, energizing the "14" operator (solenoid or remote air) connects Port #1 to Cylinder Port #4 and energizing the "12" operator connects Port #1 to Cylinder Port #2. For the following special applications, additional piping considerations are required.

EXTERNAL PILOT APPLICATIONS* - An External Pilot Supply is only required when the main valve pressure is less than 1.8 BARS on single operators (solenoid or remote air) or 0.7 BARS on double solenoid valves only. In these cases, use an External Pilot

model and supply a minimum of 1.8 BARS for single operators or a minimum of 0.7 BARS for double solenoid valves to either the "14" or "12" External Pilot Port of the valve base.

VACUUM APPLICATIONS - Use an External Pilot model as described above and also connect the vacuum source to Port #3 & 5 and leave Port#1 open to atmosphere on single pressure models. On two pressure models, reverse the single pressure piping.

SELECTOR APPLICATIONS - Use an External Pilot Model as described above if both pressures are below the minimum, otherwise use an Internal Pilot model and connect the higher pressure to Port #1 and the lower pressure to either Port #3 or 5 depending on which Cylinder Port is to be active.

TWO PRESSURE APPLICATIONS - For Internal Pilot models specify the model number for connecting either port #3 or 5, whichever is to be the higher pressure, to the Internal Pilot supply. For external Pilot models, pipe as described above for "External Pilot Application."

*Note: 1Bar = 14.5 PSIG

Function	Port size	Flow (Max)	Individual mounting & Manifold mounting	Series
5/2 - 5/3	1/4" - 3/8"	1.6 C_v	valve only	

OPERATIONAL BENEFITS

1. Balanced spool, immune to variations of pressure.
2. Short stroke with high flow.
3. The piston (booster) provides maximum shifting forces.
4. Powerful return force thanks to the combination of mechanical and air springs.
5. Bonded spool with minimum friction, shifting in a glass-like finished bore.
6. Wiping effect eliminates sticking.
7. Pilot valve with balanced poppet, high flow, short and consistent response times.
8. Long service life.

HOW TO ORDER

SINGLE PRESSURE VALVES

Pilot air	5/2 Single operator	5/2 Double operator	5/3 Closed center	5/3 Open center
Internal	MV-A1C-A111-PM- XXYZZ	MV-A1C-A211-PM- XXYZZ	MV-A1C-A312-PM- XXYZZ	MV-A1C-A311-PM- XXYZZ
External	MV-A1C-A121-PM- XXYZZ	MV-A1C-A221-PM- XXYZZ	MV-A1C-A322-PM- XXYZZ	MV-A1C-A321-PM- XXYZZ

DUAL PRESSURE VALVES

Pilot air	5/2 Single operator	5/2 Double operator	5/3 Pressure center
Internal port 3	MV-A1C-A131-PM- XXYZZ	MV-A1C-A231-PM- XXYZZ	MV-A1C-A331-PM- XXYZZ
Internal port 5	MV-A1C-A135-PM- XXYZZ	MV-A1C-A232-PM- XXYZZ	MV-A1C-A332-PM- XXYZZ
External	MV-A1C-A141-PM- XXYZZ	MV-A1C-A241-PM- XXYZZ	MV-A1C-A341-PM- XXYZZ

SOLENOID OPERATOR ▶

XX Y ZZ*

XX Voltage	Y Manual operator	ZZ Electrical connection
11 120/60, 110/50	1 Non-locking	JB Rectangular connector
12 240/60, 220/50	2 Locking	JD Rectangular connector with light
22 24/60, 24/50		JA Square connector
59 24 VDC (2.5 W)		JC Square connector with light
87 24 VDC (17.1 W)		BA Flying leads (18")
61 24 VDC (8.5 W)		

* Other options available, see page 357.
 Note : ISO valves are delivered w/o base. See page 281 for base code.

OPTIONS

- MV-A1C-A111-PM-**XXYZZ**
 - For CNOMO pilot, consult factory.
 - For universal spool replace by 6 (2 position, sgl. pressure valves only)
 - For use with single pressure sandwich regulator, replace by 5.

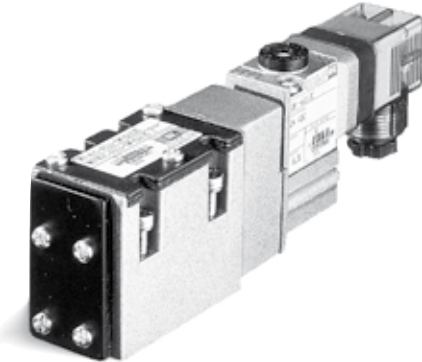

35
100
200
55
56
57
58
59

45

700
900
82

6300
6500
6600
1300

800

ISO 1
ISO 2
ISO 3
MAC 125A
MAC 250A
MAC 500A

TECHNICAL DATA

Fluid :	Compressed air, vacuum, inert gases		
Pressure range :	Internal pilot : single operator and 3 positions : 25-150 PSI	double operator : 10-150 PSI	
	External pilot : vacuum to 150 PSI		
Pilot pressure :	Single operator and 3 positions : 25-150 PSI Double operator : 10-150 PSI		
Lubrication :	Not required, if used select a medium aniline point lubricant (between 180°F to 210°F)		
Filtration :	40 μ		
Temperature range :	0°F to 120°F (-18°C to 50°C)		
Flow (at 6 bar, ΔP=1bar) :	1/4" : (1.6 C _v), 3/8" : (1.6 C _v)		
Coil :	Epoxy encapsulated - class A wires - Continuous duty		
Voltage range :	-15% to +10% of nominal voltage		
Protection :	Consult factory		
Power :	~ Inrush : 14.8 VA Holding : 10.9 VA = 1 to 17.1 W		
Response times :	24 VDC (8.5 W)	Energize : 10 ms	De-energize : 11 ms
	120/60	Energize : 7-13 ms	De-energize : 10-17 ms

Spare parts :

- Solenoid operator (power ≥ 4 W) : D1-XXAA, cover mounting screws 35206 and seal 16234.
- Pilot valve : PME-XYZZ, including seal 16337. • Pressure seal between valve and base : 16344.
- Mounting screw valve to base (x4) : 35304.

DIMENSIONS

Dimensions shown are metric (mm)

ISO 1 Manifold mounting

TYPE	A	B
JA & JC	271.6	195.8
JB & JD	294.6	207.3

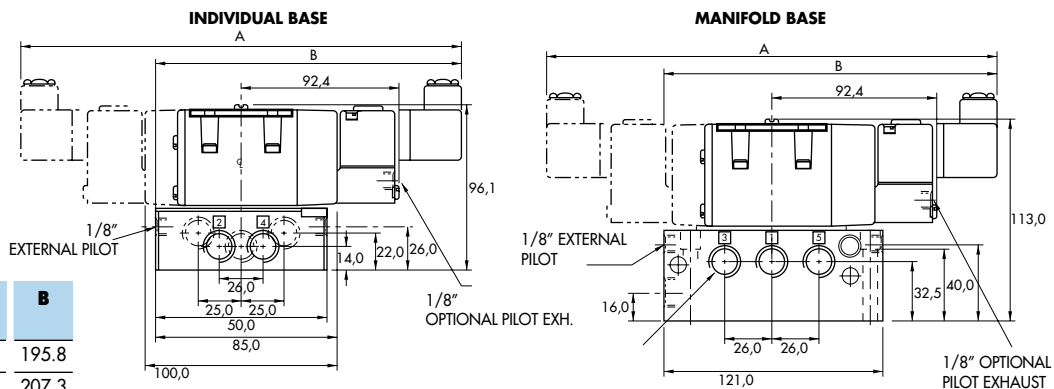

ISO 1 Individual mounting

TYPE	A	B
JA & JC	271.6	185.8
JB & JD	294.6	197.3

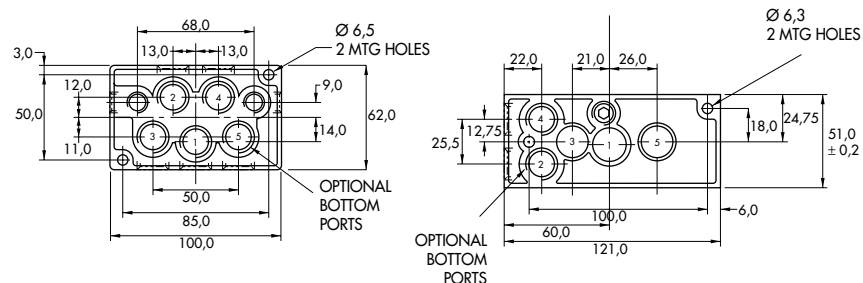

ISO 1

ISO 2

ISO 3



HOW TO ORDER

INDIVIDUAL BASE

Port size	Side ports	Side & bottom ports	Bottom cylinder ports 2 and 4.	Bottom inlet port 1
1/4" NPTF	MB-A1C-221	MB-A1C-223	MB-A1C-222	MB-A1C-224
3/8" NPTF	MB-A1C-231	MB-A1C-233	MB-A1C-232	MB-A1C-234

MANIFOLD BASE

Port size	Side ports	Bottom ports	Bottom cylinder ports 2 and 4.	Bottom inlet port 1
1/4" NPTF	MM-A1C-221	MM-A1C-223	MM-A1C-222	MM-A1C-224
3/8" NPTF	MM-A1C-231	MM-A1C-233	MM-A1C-232	MM-A1C-234

Manifold fastening kit : N-63002-01.

DIMENSIONS

Dimensions shown are metric (mm)

Individual

DIN 5599/1

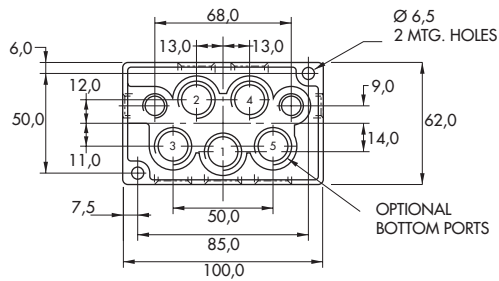
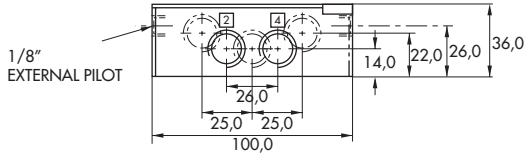

Manifold

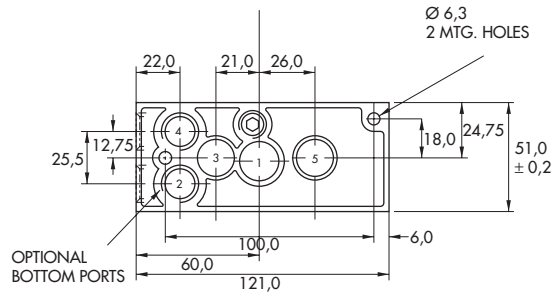
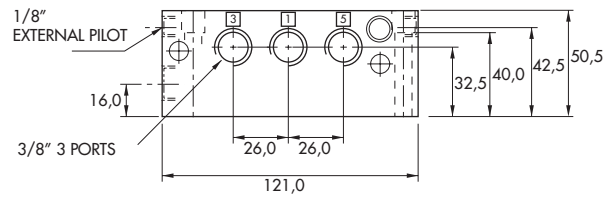

VDMA

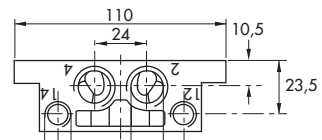
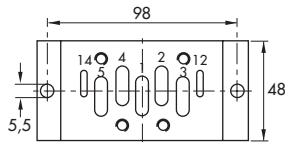
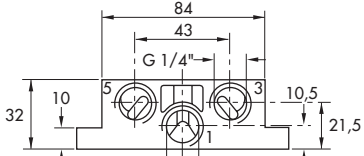

Codification table for voltages / Manual operator / Electrical connection / Wire length

VALVE CODE ► **- XX Y ZZ (-VV)**
1 2 3 4

OPTIONS AVAILABLE FOR	OPTIONS AVAILABLE FOR
<ul style="list-style-type: none"> - valves type 100 Series - pilot valves "CNOMO" 	<ul style="list-style-type: none"> - valves type 200 Series
<ul style="list-style-type: none"> - Pilot operated valves with pilots type 100 Series Series : 55 - 56 - 700 - 800 - 900 <li style="padding-left: 20px;">- 6300 - 6500 - 6600 - 1300 <li style="padding-left: 20px;">- ISO 1 - ISO 2 - ISO 3. <li style="padding-left: 20px;">- MAC 125 - MAC 250 - MAC 500 	<ul style="list-style-type: none"> - pilot operated valves with pilots type 200 Series Series : 200 - 57 - 58 - 59.
<ul style="list-style-type: none"> - Pilot operated valves with pilots "CNOMO" Series : ISO1 - ISO2 - ISO3 	