

Individual mounting

sub-base non "plug-in"	sub-base "plug-in"
------------------------	--------------------

Series

Manifold mounting

sub-base non "plug-in"	sub-base "plug-in"
------------------------	--------------------

35

100

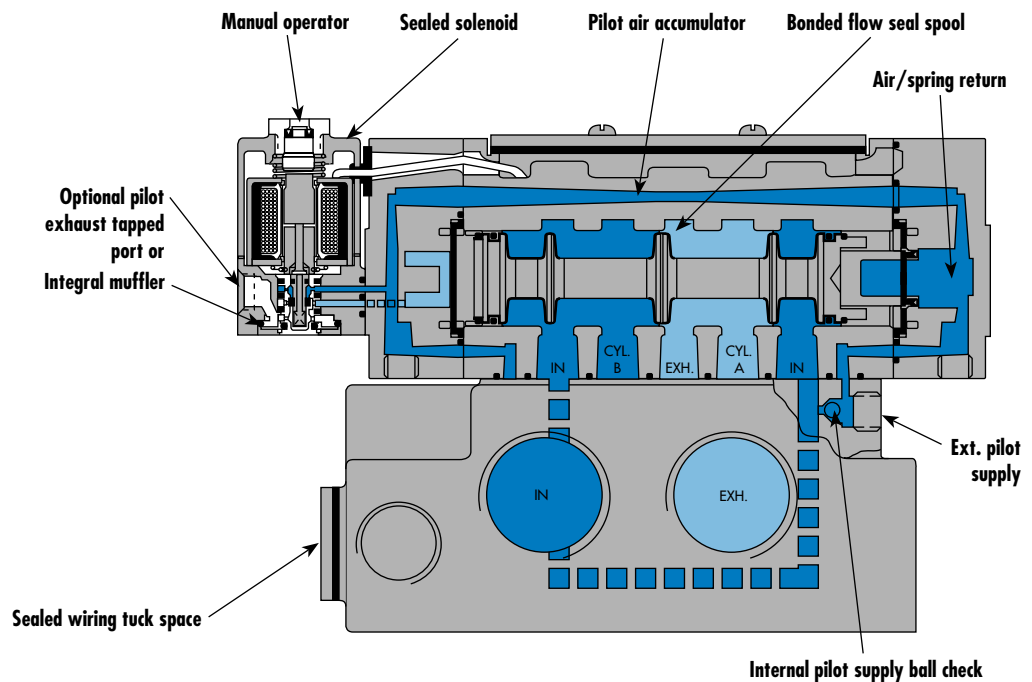

200

55

56

57

58

59

45

700

900

82

6300

6500

**6600**

1300

800

ISO 1

ISO 2

ISO 3

MAC 125A

MAC 250A

MAC 500A

**SERIES FEATURES**

- The patented MACSOLENOID® with its non-burn out feature on AC service.
- A large checked accumulator for consistent shifting on single and double solenoid models.
- A plug-in design that provides for internal or external pilot with or without lights and all electrical and air plumbing in the base.
- Non-lubricated or lubricated service.
- Optional low wattage DC solenoids down to 1 watt.
- Optional indicator lights, and various types of manual operators.
- Non plug-in or external plug-in models are available.

## SPOOL CONFIGURATIONS

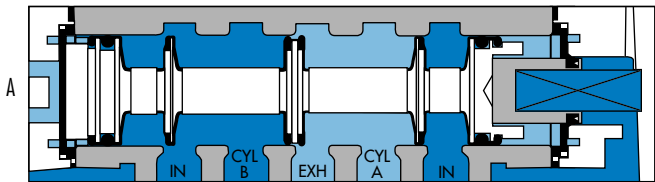

2 POS. SINGLE OPERATOR SPRING RETURN  
B ACTUATED SHOWN

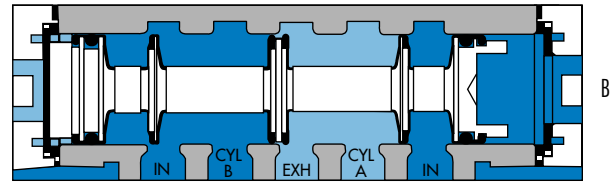

2 POS. DOUBLE OPERATOR  
B ACTUATED SHOWN

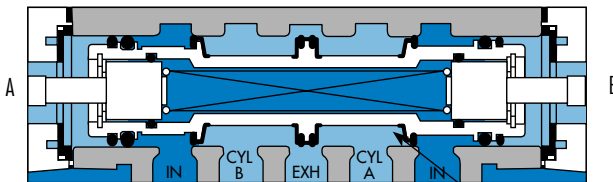

3 POS. OPEN CENTER  
CENTER POSITION SHOWN

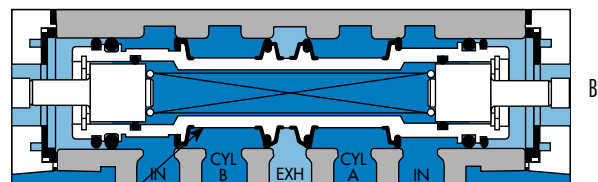

3 POS. CLOSED CENTER  
CENTER POSITION SHOWN

PATENTED  
AIR/SPRING  
CENTERING

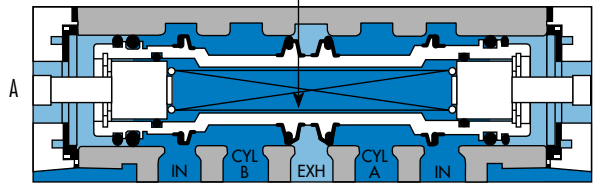

3 POS. PRESSURE CENTER  
CENTER POSITION SHOWN

## VALVE CONFIGURATIONS AVAILABLE

The versatile 6600 Series provides high flow, extremely fast response, and long life in a compact package and is available in the following configurations:

- 2-Pos., single or double operators (solenoid or remote air).
- 3-Pos., double operator-Closed Center, Open Center or Pressure Center (solenoid or remote air).
- Single pressure or dual pressure.
- Individual base.
- Internal pilot or for Vacuum to 25 PSI main valve pressures, external pilot.
- Manual and mechanical operators available.

## REMOTE AIR PILOT OPERATED VALVES

These remote air versions feature:

- A large checked accumulator for air/spring return on single remote air models.
- All piping connections, including the remote air pilot supply, in the base.
- Non-lubricated or lubricated service.

## REMOTE AIR PILOT, PILOT OPERATED VALVES

These special air versions have the same features as the remote air pilot operated models, but additionally feature:

- A manual operator and indicator.
- Ability to use a pilot signal pressure different from the main valve pressure. Pilot signal can be from 20 to 150 PSIG, regardless of main valve pressure.

Function	Port size	Flow (Max)	Individual mounting	Series
<b>4/2 - 4/3</b>	<b>3/4" - 1"</b>	<b>9.6 C<sub>v</sub></b>	sub-base non "plug-in"	

### OPERATIONAL BENEFITS

- Balanced spool, immune to variations of pressure.
- Short stroke with high flow.
- High shifting forces.
- Checked accumulator guarantees maximum pilot pressure.
- Powerful return force thanks to the combination of mechanical and air springs.
- Bonded spool with minimum friction, shifting in a glass-like finished bore.
- Wiping effect eliminates sticking.
- Pilot valve with balanced poppet, high flow, short and consistent response times.

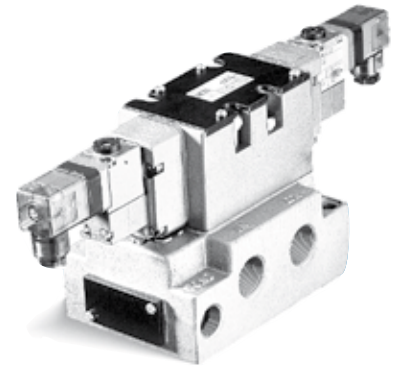

35  
100  
200  
55  
56  
57  
58  
59

### HOW TO ORDER

Port size	Pilot air	4/2 Single operator	4/2 Double operator	4/3 Closed center	4/3 Open center	4/3 Pressure center
<b>Valve less base</b>		6612A-000-PM- <b>XXYZZ</b>	6622A-000-PM- <b>XXYZZ</b>	6632A-000-PM- <b>XXYZZ</b>	6642A-000-PM- <b>XXYZZ</b>	6652A-000-PM- <b>XXYZZ</b>
<b>sub-base</b>	Internal	6612A-231-PM- <b>XXYZZ</b>	6622A-231-PM- <b>XXYZZ</b>	6632A-231-PM- <b>XXYZZ</b>	6642A-231-PM- <b>XXYZZ</b>	6652A-231-PM- <b>XXYZZ</b>
<b>3/4" NPTF</b>	External	6612A-241-PM- <b>XXYZZ</b>	6622A-241-PM- <b>XXYZZ</b>	6632A-241-PM- <b>XXYZZ</b>	6642A-241-PM- <b>XXYZZ</b>	6652A-241-PM- <b>XXYZZ</b>
<b>sub-base</b>	Internal	6612A-331-PM- <b>XXYZZ</b>	6622A-331-PM- <b>XXYZZ</b>	6632A-331-PM- <b>XXYZZ</b>	6642A-331-PM- <b>XXYZZ</b>	6652A-331-PM- <b>XXYZZ</b>
<b>1" NPTF</b>	External	6612A-341-PM- <b>XXYZZ</b>	6622A-341-PM- <b>XXYZZ</b>	6632A-341-PM- <b>XXYZZ</b>	6642A-341-PM- <b>XXYZZ</b>	6652A-341-PM- <b>XXYZZ</b>

Note : Above codes shown are for side ports.

### SOLENOID OPERATOR ▶

XX Voltage		Y Manual operator	ZZ Electrical connection
11	120/60, 110/50	1 Non-locking	JB Rectangular connector
12	240/60, 220/50	2 Locking	JD Rectangular connector with light
22	24/60, 24/50		JA Square connector
59	24 VDC (2.5 W)		JC Square connector with light
87	24 VDC (17.1 W)		BA Flying leads (18")
61	24 VDC (8.5 W)		

\* Other options available, see page 357.

### OPTIONS

- 6612A-XXX-PM-**XXYZZ**
  - For piped pilot exhaust replace M by P.
  - For dual pressure valve, replace by 4.

MODIFICATIONS		
MOD. N°	DESCRIPTION	MODEL AVAILABILITY
<b>0002</b>	Bottom inlet, exh. & cyl ports (side ports plugged)	3/4" individual base
<b>0004</b>	Full side porting and additional. Bottom inlet, exh. & cyl ports	3/4" individual base
<b>0112</b>	Side inlet & exhaust with bottom cyl. ports (side cyl.ports plugged)	3/4" individual base

**TO ORDER** - Add the appropriate modification number after the valve number;  
**EXAMPLE** : 6612A-231-PM-111JA **MOD 0002**

- Note : 1. The valve less base is always the same for internal or external pilot. These options are effected in the base.  
 2. Bottom ports : Refer to modification table.  
 3. To order bases without the valve, choose the base from the above table, then add 6600A as a prefix. Example 6600A-231.  
 4. 2 position and 3 position valve bodies are not interchangeable.

700  
900  
82  
6300  
6500  
6600  
1300  
800  
ISO 1  
ISO 2  
ISO 3  
MAC 125A  
MAC 250A  
MAC 500A

**TECHNICAL DATA**

<b>Fluid :</b>	Compressed air, vacuum, inert gases		
<b>Pressure range :</b>	Internal pilot : single operator and 3 positions : 25-150 PSI	double operator : 10-150 PSI	
	External pilot : vacuum to 150 PSI		
<b>Pilot pressure :</b>	Single operator and 3 positions : 25-150 PSI Double operator : 10-150 PSI		
<b>Lubrication :</b>	Not required, if used select a medium aniline point lubricant (between 180°F to 210°F)		
<b>Filtration :</b>	40 µ		
<b>Temperature range :</b>	0°F to 120°F (-18°C to 50°C)		
<b>Flow (at 6 bar, ΔP=1bar) :</b>	3/4" : (9.0 C <sub>v</sub> ), 1" : (9.6 C <sub>v</sub> )		
<b>Coil :</b>	Epoxy encapsulated - class A wires - Continuous duty		
<b>Voltage range :</b>	-15% to +10% of nominal voltage		
<b>Protection :</b>	Consult factory		
<b>Power :</b>	~ Inrush : 14.8 VA Holding : 10.9 VA = 1 to 17.1 W		
<b>Response times :</b>	24 VDC (8.5 W)	Energize : 18 ms	De-energize : 20 ms
	120/60	Energize : 15-25 ms	De-energize : 19-28 ms

- Spare parts :
- Solenoid operator (power ≥ 4 W) : D1-XXAA, cover mounting screws 35206 and seal 16234.
  - Pilot valve : PME-XXYZZ, including seal 16337. • Pressure seal between valve and base : 16436.
  - Mounting screw valve to base (x4) : 35416.

- Options :
- BSPP threads.

**DIMENSIONS**

Dimensions shown are metric (mm)

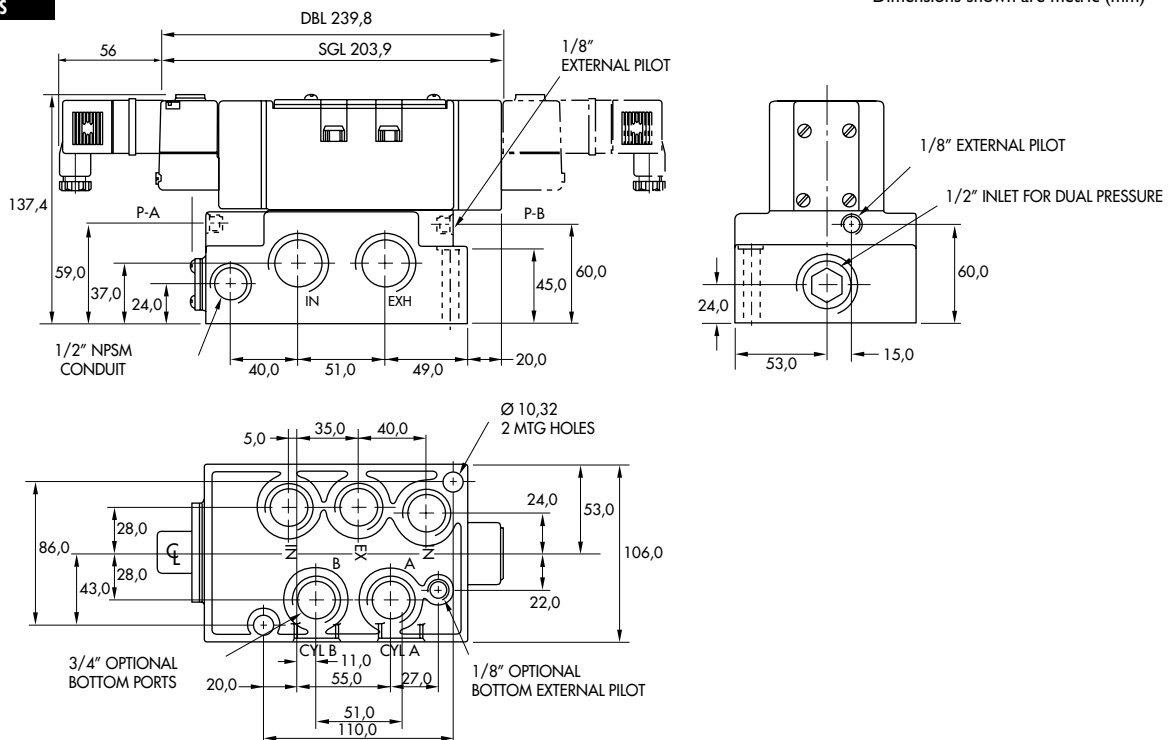

Function	Port size	Flow [Max]	Individual mounting	Series
<b>4/2 - 4/3</b>	<b>3/4" - 1"</b>	<b>9.6 C<sub>v</sub></b>	sub-base "plug-in"	

### OPERATIONAL BENEFITS

1. Balanced spool, immune to variations of pressure.
2. Short stroke with high flow.
3. High shifting forces.
4. Checked accumulator guarantees maximum pilot pressure.
5. Powerful return force thanks to the combination of mechanical and air springs.
6. Bonded spool with minimum friction, shifting in a glass-like finished bore.
7. Wiping effect eliminates sticking.
8. Pilot valve with balanced poppet, high flow, short and consistent response times.

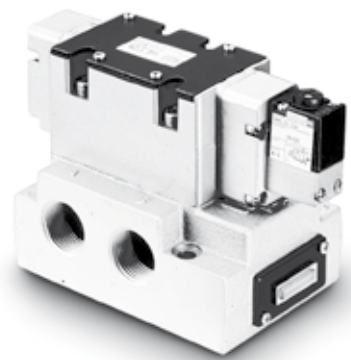

35  
100  
200  
55  
56  
57  
58  
59

### HOW TO ORDER

Port size	Pilot air	4/2 Single operator	4/2 Double operator	4/3 Closed center	4/3 Open center	4/3 Pressure center
<b>Valve less base</b>		6611A-000-PM-XXYDA	6621A-000-PM-XXYDA	6631A-000-PM-XXYDA	6641A-000-PM-XXYDA	6651A-000-PM-XXYDA
<b>sub-base</b>	Internal	6611A-211-PM-XXYDA	6621A-211-PM-XXYDA	6631A-211-PM-XXYDA	6641A-211-PM-XXYDA	6651A-211-PM-XXYDA
<b>3/4" NPTF</b>	External	6611A-221-PM-XXYDA	6621A-221-PM-XXYDA	6631A-221-PM-XXYDA	6641A-221-PM-XXYDA	6651A-221-PM-XXYDA
<b>sub-base</b>	Internal	6611A-311-PM-XXYDA	6621A-311-PM-XXYDA	6631A-311-PM-XXYDA	6641A-311-PM-XXYDA	6651A-311-PM-XXYDA
<b>1" NPTF</b>	External	6611A-321-PM-XXYDA	6621A-321-PM-XXYDA	6631A-321-PM-XXYDA	6641A-321-PM-XXYDA	6651A-321-PM-XXYDA

Note : Above codes shown are for side ports without lights.

700  
900  
82

### SOLENOID OPERATOR >

XX Y DA\*

XX Voltage	Y Manual operator
11 120/60, 110/50	1 Non-locking
12 240/60, 220/50	2 Locking
22 24/60, 24/50	
59 24 VDC (2.5 W)	
87 24 VDC (17.1 W)	
61 24 VDC (8.5 W)	

\* Other options available, see page 357.

### OPTIONS

6611A-XXX-PM-XXYDA

- For piped pilot exhaust replace M by P.
- For dual pressure valve replace by 4 (no light), by 5 (sgl. light), by 6 (dbl. light).
- For lights on base, replace by 2 (sgl. light), by 3 (dbl. light).
- For lights on valve body, replace by 3.

6300  
6500  
6600  
1300  
800  
ISO 1  
ISO 2  
ISO 3  
MAC 125A  
MAC 250A  
MAC 500A

MODIFICATIONS		
MOD. N°	DESCRIPTION	MODEL AVAILABILITY
0002	Bottom inlet, exh. & cyl ports (side ports plugged)	3/4" individual base
0004	Full side porting and additional bottom inlet, exh. & cyl ports	3/4" individual base
0112	Side inlet & exhaust with bottom cyl. ports (side cyl.ports plugged)	3/4" individual base

- Note : 1. The valve less base is always the same for internal or external pilot. These options are effected in the base.  
2. Bottom ports : Refer to modification table.  
3. To order bases without the valve, choose the base from the above table, then add 6600A as a prefix. Example 6600A-211.  
4. 2 position and 3 position valve bodies are not interchangeable.

**TO ORDER** - Add the appropriate modification number after the valve number;  
**EXAMPLE** : 6611A-211-PM-111DA **MOD 0002**

**TECHNICAL DATA**

<b>Fluid :</b>	Compressed air, vacuum, inert gases		
<b>Pressure range :</b>	Internal pilot : single operator and 3 positions : 25-150 PSI	double operator : 10-150 PSI	
	External pilot : vacuum to 150 PSI		
<b>Pilot pressure :</b>	Single operator and 3 positions : 25-150 PSI Double operator : 10-150 PSI		
<b>Lubrication :</b>	Not required, if used select a medium aniline point lubricant (between 180°F to 210°F)		
<b>Filtration :</b>	40 µ		
<b>Temperature range :</b>	0°F to 120°F (-18°C to 50°C)		
<b>Flow (at 6 bar, ΔP=1bar) :</b>	3/4" : (9.0 C <sub>v</sub> ), 1" : (9.6 C <sub>v</sub> )		
<b>Coil :</b>	Epoxy encapsulated - class A wires - Continuous duty		
<b>Voltage range :</b>	-15% to +10% of nominal voltage		
<b>Protection :</b>	Consult factory		
<b>Power :</b>	- Inrush : 14.8 VA	Holding : 10.9 VA	
	= 1 to 17.1 W		
<b>Response times :</b>	24 VDC (8.5 W)	Energize : 18 ms	De-energize : 20 ms
	120/60	Energize : 15-25 ms	De-energize : 19-28 ms

Spare parts :

- Solenoid operator (power ≥ 4 W) : D1-XXBE, cover mounting screws 35206 and seal 16234.
- Pilot valve : PME-XXYDA-BE, including seal 16337. • Pressure seal between valve and base : 16436.
- Mounting screw valve to base (x4) : 35416.

Options :

- BSPP threads.

**DIMENSIONS**

Dimensions shown are metric (mm)

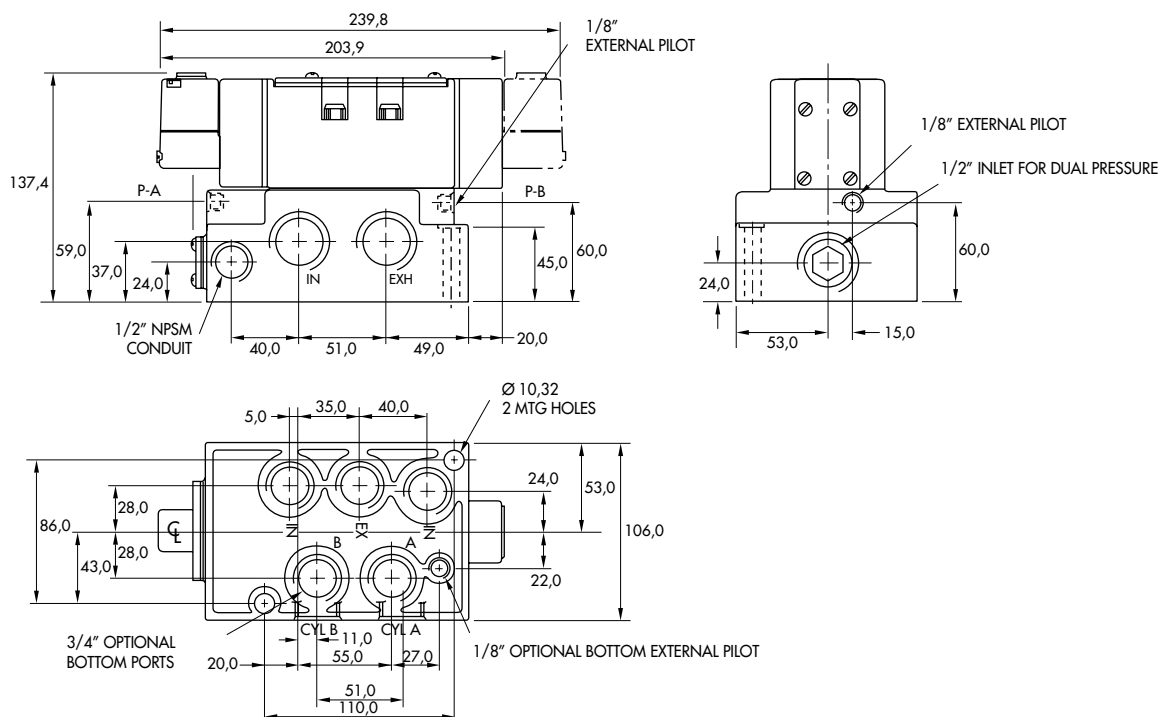

Function	Port size	Flow (Max)	Manifold mounting	Series
<b>4/2 - 4/3</b>	<b>3/4" - 1" - 1 1/4"</b>	<b>9.6 C<sub>v</sub></b>	sub-base non "plug-in"	

### OPERATIONAL BENEFITS

- Balanced spool, immune to variations of pressure.
- Short stroke with high flow.
- High shifting forces.
- Checked accumulator guarantees maximum pilot pressure.
- Powerful return force thanks to the combination of mechanical and air springs.
- Bonded spool with minimum friction, shifting in a glass-like finished bore.
- Wiping effect eliminates sticking.
- Pilot valve with balanced poppet, high flow, short and consistent response times.

### HOW TO ORDER

Port size	Pilot air	4/2 Single operator	4/2 Double operator	4/3 Closed center	4/3 Open center	4/3 Pressure center
<b>Valve less base</b>		6612A-000-PM- <b>XXYZZ</b>	6622A-000-PM- <b>XXYZZ</b>	6632A-000-PM- <b>XXYZZ</b>	6642A-000-PM- <b>XXYZZ</b>	6652A-000-PM- <b>XXYZZ</b>
<b>sub-base</b>	Internal	6612A-431-PM- <b>XXYZZ</b>	6622A-431-PM- <b>XXYZZ</b>	6632A-431-PM- <b>XXYZZ</b>	6642A-431-PM- <b>XXYZZ</b>	6652A-431-PM- <b>XXYZZ</b>
<b>3/4" NPTF</b>	External	6612A-441-PM- <b>XXYZZ</b>	6622A-441-PM- <b>XXYZZ</b>	6632A-441-PM- <b>XXYZZ</b>	6642A-441-PM- <b>XXYZZ</b>	6652A-441-PM- <b>XXYZZ</b>
<b>sub-base</b>	Internal	6612A-531-PM- <b>XXYZZ</b>	6622A-531-PM- <b>XXYZZ</b>	6632A-531-PM- <b>XXYZZ</b>	6642A-531-PM- <b>XXYZZ</b>	6652A-531-PM- <b>XXYZZ</b>
<b>1" NPTF</b>	External	6612A-541-PM- <b>XXYZZ</b>	6622A-541-PM- <b>XXYZZ</b>	6632A-541-PM- <b>XXYZZ</b>	6642A-541-PM- <b>XXYZZ</b>	6652A-541-PM- <b>XXYZZ</b>
<b>sub-base</b>	Internal	6612A-631-PM- <b>XXYZZ</b>	6622A-631-PM- <b>XXYZZ</b>	6632A-631-PM- <b>XXYZZ</b>	6642A-631-PM- <b>XXYZZ</b>	6652A-631-PM- <b>XXYZZ</b>
<b>1 1/4" NPTF</b>	External	6612A-641-PM- <b>XXYZZ</b>	6622A-641-PM- <b>XXYZZ</b>	6632A-641-PM- <b>XXYZZ</b>	6642A-641-PM- <b>XXYZZ</b>	6652A-641-PM- <b>XXYZZ</b>

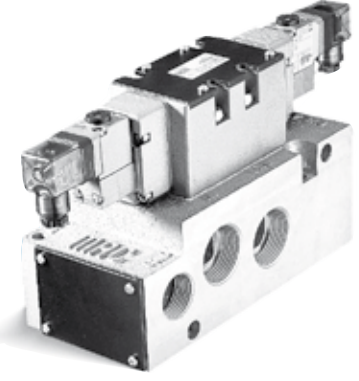

35  
100  
200  
55  
56  
57  
58  
59  
45  
700  
900  
82  
6300  
6500  
6600  
1300  
800  
ISO 1  
ISO 2  
ISO 3  
MAC 125A  
MAC 250A  
MAC 500A

Note : Above codes shown are for side ports.

### SOLENOID OPERATOR >

XX Voltage		Y Manual operator		ZZ Electrical connection	
11	120/60, 110/50	1	Non-locking	JB	Rectangular connector
12	240/60, 220/50	2	Locking	JD	Rectangular connector with light
22	24/60, 24/50			JA	Square connector
59	24 VDC (2.5 W)			JC	Square connector with light
87	24 VDC (17.1 W)			BA	Flying leads (18")
61	24 VDC (8.5 W)				

\* Other options available, see page 357.

Note : Photo shown with JC connector.

### OPTIONS

- 6612A-XXX-PM-**XXYDA**
- For piped pilot exhaust replace M by P.
  - For dual pressure valve, replace by 4.

MODIFICATIONS		
MOD. N°	DESCRIPTION	MODEL AVAILABILITY
<b>0210</b>	1 1/4" Bottom inlet	Manifold base
<b>0364</b>	1 1/4" Bottom inlet, 3/4" or 1" Bottom cyl.	Manifold base
<b>0112</b>	Side inlet & exhaust with bottom cyl. ports (side cyl.ports plugged)	1" Manifold base

**TO ORDER** - Add the appropriate modification number after the valve number;  
**EXAMPLE** : 6612A-431-PM-111JA **MOD 0364**

- Note : 1. The valve less base is always the same for internal or external pilot. These options are effected in the manifold.  
 2. Bottom ports : Refer to modification table.  
 3. To order manifolds without the valve, choose the manifold from the above table, then add 6600A as a prefix. Example 6600A-431.  
 4. When ordering an external pilot connection for manifold bases, a common external pilot port is standard. One connection only is required for all the valves in the manifold whether single or double solenoid.  
 5. 2 position and 3 position valve bodies are not interchangeable.

**TECHNICAL DATA**

<b>Fluid :</b>	Compressed air, vacuum, inert gases		
<b>Pressure range :</b>	Internal pilot : single operator and 3 positions : 25-150 PSI	double operator : 10-150 PSI	
	External pilot : vacuum to 150 PSI		
<b>Pilot pressure :</b>	Single operator and 3 positions : 25-150 PSI Double operator : 10-150 PSI		
<b>Lubrication :</b>	Not required, if used select a medium aniline point lubricant (between 180°F to 210°F)		
<b>Filtration :</b>	40 μ		
<b>Temperature range :</b>	0°F to 120°F (-18°C to 50°C)		
<b>Flow (at 6 bar, ΔP=1bar) :</b>	3/4" : (9.0 C <sub>v</sub> ), 1" : (9.6 C <sub>v</sub> ), 1 1/4" : (9.6 C <sub>v</sub> )		
<b>Coil :</b>	Epoxy encapsulated - class A wires - Continuous duty		
<b>Voltage range :</b>	-15% to +10% of nominal voltage		
<b>Protection :</b>	Consult factory		
<b>Power :</b>	~ Inrush : 14.8 VA	Holding : 10.9 VA	
	= 1 to 17.1 W		
<b>Response times :</b>	24 VDC (8.5 W)	Energize : 18 ms	De-energize : 20 ms
	120/60	Energize : 15-25 ms	De-energize : 19-28 ms

Spare parts :

- Solenoid operator (power ≥ 4 W) : D1-XXAA, cover mounting screws 35206 and seal 16234.
- Pilot valve : PME-XXYZZ, including seal 16337. • Pressure seal between valve and base : 16436.
- Mounting screw valve to base (x4) : 35416. • Tie-rod (x2) : 19789. • Fastening kit : N-66002-01.
- Inlet & exhaust isolator : 28367.

Options :

- BSPP threads.

**DIMENSIONS**

Dimensions shown are metric (mm)

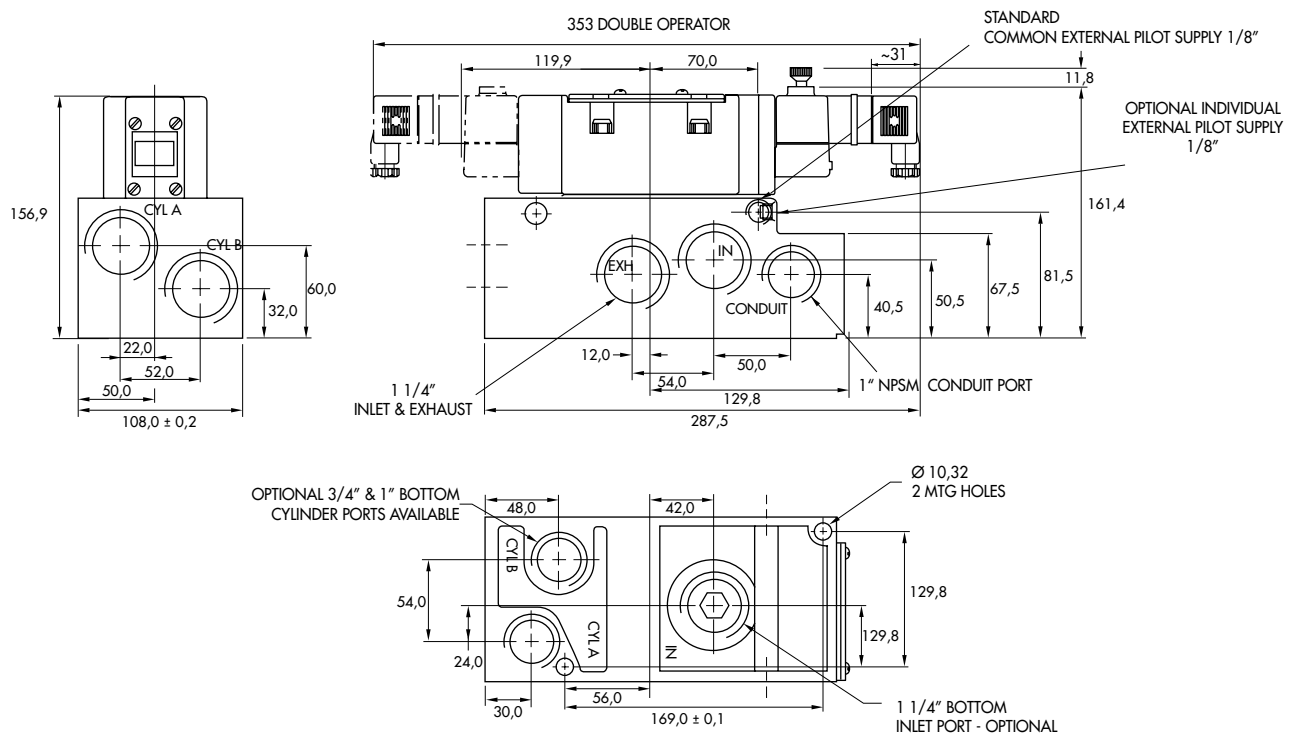



Function	Port size	Flow [Max]	Manifold mounting	Series
<b>4/2 - 4/3</b>	<b>3/4" - 1" - 1 1/4"</b>	<b>9.6 C<sub>v</sub></b>	sub-base "plug-in"	

### OPERATIONAL BENEFITS

- Balanced spool, immune to variations of pressure.
- Short stroke with high flow.
- High shifting forces.
- Checked accumulator guarantees maximum pilot pressure.
- Powerful return force thanks to the combination of mechanical and air springs.
- Bonded spool with minimum friction, shifting in a glass-like finished bore.
- Wiping effect eliminates sticking.
- Pilot valve with balanced poppet, high flow, short and consistent response times.

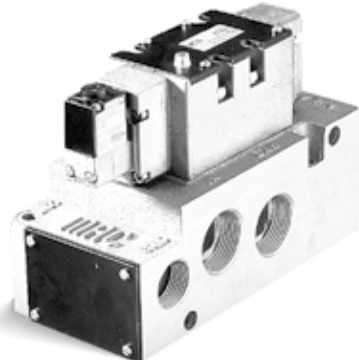

35  
100  
200  
55  
56  
57  
58  
59

### HOW TO ORDER

Port size	Pilot air	4/2 Single operator	4/2 Double operator	4/3 Closed center	4/3 Open center	4/3 Pressure center
<b>Valve less base</b>		6611A-000-PM- <b>XXY</b> DA	6621A-000-PM- <b>XXY</b> DA	6631A-000-PM- <b>XXY</b> DA	6641A-000-PM- <b>XXY</b> DA	6651A-000-PM- <b>XXY</b> DA
<b>sub-base</b>	Internal	6611A-411-PM- <b>XXY</b> DA	6621A-411-PM- <b>XXY</b> DA	6631A-411-PM- <b>XXY</b> DA	6641A-411-PM- <b>XXY</b> DA	6651A-411-PM- <b>XXY</b> DA
<b>3/4" NPTF</b>	External	6611A-421-PM- <b>XXY</b> DA	6621A-421-PM- <b>XXY</b> DA	6631A-421-PM- <b>XXY</b> DA	6641A-421-PM- <b>XXY</b> DA	6651A-421-PM- <b>XXY</b> DA
<b>sub-base</b>	Internal	6611A-511-PM- <b>XXY</b> DA	6621A-511-PM- <b>XXY</b> DA	6631A-511-PM- <b>XXY</b> DA	6641A-511-PM- <b>XXY</b> DA	6651A-511-PM- <b>XXY</b> DA
<b>1" NPTF</b>	External	6611A-521-PM- <b>XXY</b> DA	6621A-521-PM- <b>XXY</b> DA	6631A-521-PM- <b>XXY</b> DA	6641A-521-PM- <b>XXY</b> DA	6651A-521-PM- <b>XXY</b> DA
<b>sub-base</b>	Internal	6611A-611-PM- <b>XXY</b> DA	6621A-611-PM- <b>XXY</b> DA	6631A-611-PM- <b>XXY</b> DA	6641A-611-PM- <b>XXY</b> DA	6651A-611-PM- <b>XXY</b> DA
<b>1 1/4" NPTF</b>	External	6611A-621-PM- <b>XXY</b> DA	6621A-621-PM- <b>XXY</b> DA	6631A-621-PM- <b>XXY</b> DA	6641A-621-PM- <b>XXY</b> DA	6651A-621-PM- <b>XXY</b> DA

Note : Above codes shown are for side cylinder ports without lights.

### SOLENOID OPERATOR >

XX Voltage	Y Manual operator
<b>11</b> 120/60, 110/50	<b>1</b> Non-locking
<b>12</b> 240/60, 220/50	<b>2</b> Locking
<b>22</b> 24/60, 24/50	
<b>59</b> 24 VDC (2.5 W)	
<b>87</b> 24 VDC (17.1 W)	
<b>61</b> 24 VDC (8.5 W)	

\* Other options available, see page 357.

### OPTIONS

6611A-XXX-PM- <b>XXY</b> DA	- For dual pressure valve replace by 4 (no light), by 5 (sgl. light), by 6 (dbl. light).
	- For piped pilot exhaust replace M by P.
	- For lights on manifold, replace by 2 (sgl. light), by 3 (dbl. light).
	- For lights on valve body, replace by 3.

MOD. N°	DESCRIPTION	MODEL AVAILABILITY
<b>0210</b>	1 1/4" Bottom inlet	Manifold base
<b>0364</b>	1 1/4" Bottom inlet, 3/4" or 1" Bottom cyl.	Manifold base
<b>0112</b>	Side inlet & exhaust with bottom cyl. ports (side cyl.ports plugged)	1" Manifold base

**TO ORDER** - Add the appropriate modification number after the valve number;  
**EXAMPLE** : 6611A-411-PM-111DA **MOD 0364**

- Note :
- The valve less base is always the same for internal or external pilot. These options are effected in the manifold.
  - Bottom ports : Refer to modification table.
  - To order manifolds without the valve, choose the manifold from the above table, then add 6600A as a prefix. Example 6600A-411.
  - When ordering an external pilot connection for manifold bases, a common external pilot port is standard. One connection only is required for all the valves in the manifold whether single or double solenoid.
  - 2 position and 3 position valve bodies are not interchangeable.

Consult "Precautions" page 364 before use, installation or service of MAC Valves

45  
700  
900  
82  
6300  
6500  
6600  
1300  
800  
ISO 1  
ISO 2  
ISO 3  
MAC 125A  
MAC 250A  
MAC 500A

**TECHNICAL DATA**

<b>Fluid :</b>	Compressed air, vacuum, inert gases		
<b>Pressure range :</b>	Internal pilot : single operator and 3 positions : 25-150 PSI	double operator : 10-150 PSI	
	External pilot : vacuum to 150 PSI		
<b>Pilot pressure :</b>	Single operator and 3 positions : 25-150 PSI Double operator : 10-150 PSI		
<b>Lubrication :</b>	Not required, if used select a medium aniline point lubricant (between 180°F to 210°F)		
<b>Filtration :</b>	40 μ		
<b>Temperature range :</b>	0°F to 120°F (-18°C to 50°C)		
<b>Flow (at 6 bar, ΔP=1bar) :</b>	3/4" : (9.0 C <sub>v</sub> ), 1" : (9.6 C <sub>v</sub> ), 1 1/4" : (9.6 C <sub>v</sub> )		
<b>Coil :</b>	Epoxy encapsulated - class A wires - Continuous duty		
<b>Voltage range :</b>	-15% to +10% of nominal voltage		
<b>Protection :</b>	Consult factory		
<b>Power :</b>	~ Inrush : 14.8 VA      Holding : 10.9 VA = 1 to 17.1 W		
<b>Response times :</b>	24 VDC (8.5 W)	Energize : 18 ms	De-energize : 20 ms
	120/60	Energize : 15-25 ms	De-energize : 19-28 ms

Spare parts :

- Solenoid operator (power ≥ 4 W) : D1-XXBE, cover mounting screws 35206 and seal 16234.
- Pilot valve : PME-XXYDA-BE, including seal 16337. • Pressure seal between valve and base : 16436.
- Mounting screw valve to base (x4) : 35416. • Tie-rod (x2) : 19789. • Fastening kit : N-66002-01.
- Inlet & exhaust isolator : 28367.

Options :

- BSPP threads.

**DIMENSIONS**

Dimensions shown are metric (mm)

