

ISO 6431/6432 Cylinders

ISO 6431, VDMA 24562

Air Cylinders

11.2-11.6

ISO 6431 Accessories

11.7-11.9

ISO 6432/CETOP Cylinders

11.10-11.22

ISO 6432 Accessories

11.23

PCE Air Cylinders

11.24-11.26

PCE Accessories

11.27

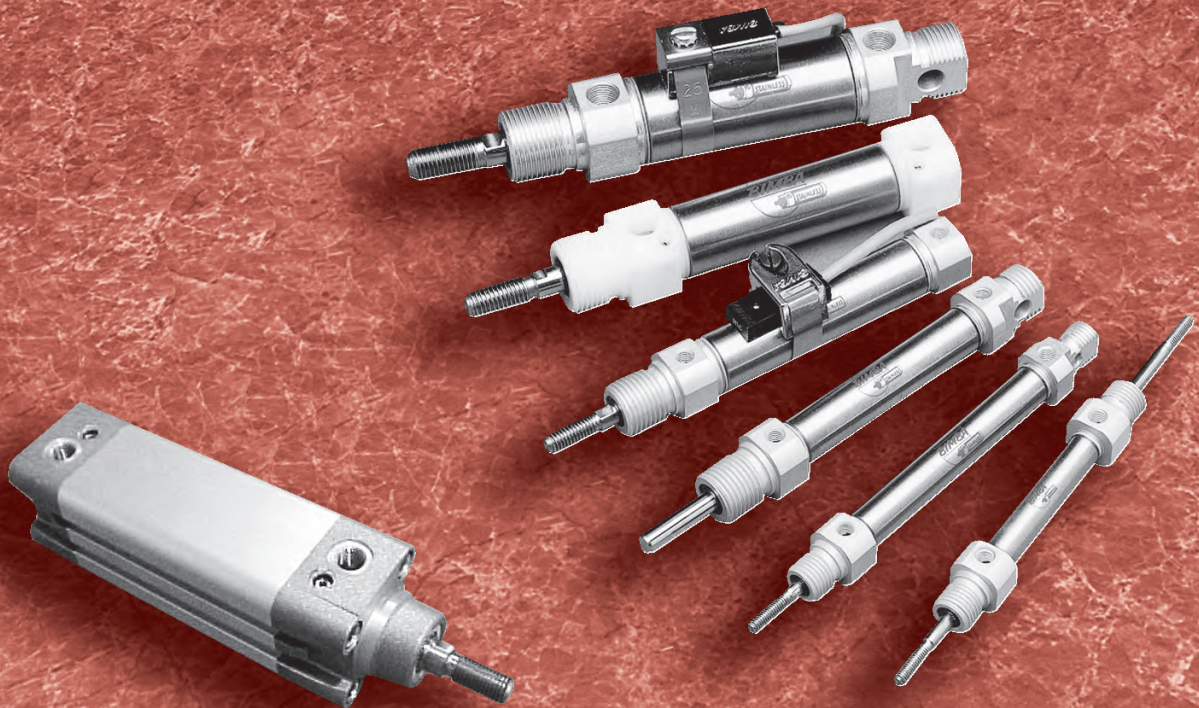

Bimba ISO 6431, VDMA 24562 Air Cylinders

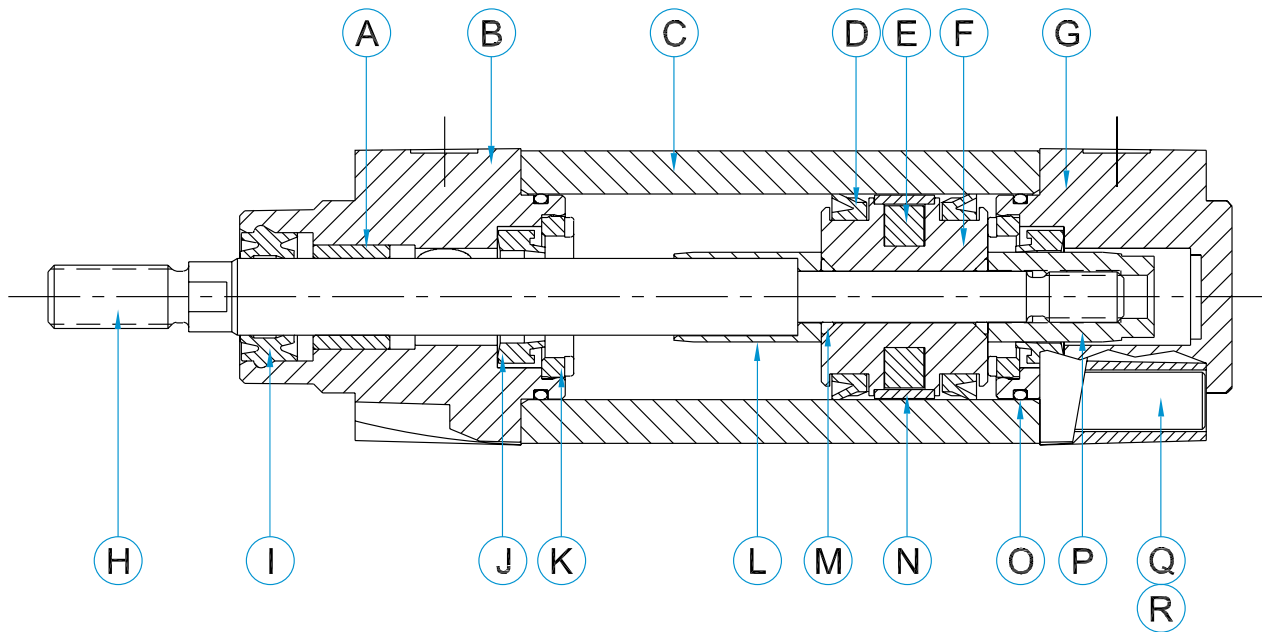

Item	Component	Material
A	Rod Bearing	Sintered Bronze
B	Rod Guide	Aluminum Alloy
C	Body	Anodized Aluminum Alloy
D	Piston Seal (2)	Polyurethane
E	Magnet	Plastoferrite
F	Piston	Aluminum Alloy
G	Rear Head	Aluminum Alloy
H	Piston Rod	Stainless Steel
I	Rod Seal/Wiper	Polyurethane
J	Cushion Seal (2)	Buna-N
K	Cushion Seal Retainer (2)	Nylon 66
L	Cushion Sleeve	Aluminum Alloy
M	Piston O-Ring (2)	Buna-N
N	Piston Bearing Ring	Nylon 66
O	Body Seal (2)	Buna-N
P	Piston Nut/Cushion	Aluminum Alloy
Q	Tie Rod Nut (8)	Zinc Plated Steel
R	Tie Rod (4)	Stainless Steel
Not Shown	Cushion Adjustable Screw (2) Cushion Adjustable Seal (2)	Plated Brass Buna-N

Bimba ISO 6431, VDMA 24562 Air Cylinders

How to Order

The Model Number for all Bimba ISO 6431 cylinders consists of four alphanumeric clusters. These designate type, bore size and stroke length, and options.

A variety of *Mounting Kits* are available for use with each basic cylinder. Please select the required mounting type from the specifications shown in the appropriate Bore Size Section.

Please refer to the charts below for an example of Model Number **AB-32-100-CB**. This is an ISO 6431 Type Cylinder, with 32mm Bore Size, 100mm Stroke Size. **Cushions and Magnetic Piston are standard.**

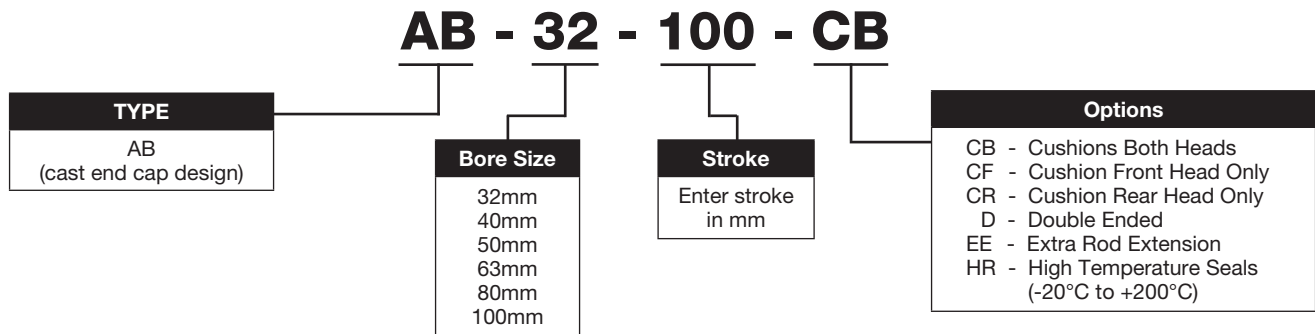

General Specifications

Specifications	Cylinder Bore
Operating Pressure Range	0.5 bar to 10 bar
Operating Temperature Range	0°C to +80°C
Stroke Lengths	1mm to 2800mm

Note: Position Feedback available as a special option.

ISO 6431 VDMA Price List

Basic Model	32mm	40mm	50mm	63mm	80mm	100mm
AB-00-□ -	\$110.10	\$118.30	\$130.00	\$153.70	\$206.90	\$254.00
<i>add per mm stroke</i>	0.12	0.15	0.20	0.23	0.32	0.39

Options	32mm	40mm	50mm	63mm	80mm	100mm
D - Double Rod Option	\$25.70	\$34.10	\$44.40	\$48.30	\$58.00	\$90.60
<i>add per mm stroke</i>	0.17	0.19	0.26	0.30	0.45	0.51
HR - High Temperature	53.90	58.80	59.70	63.80	97.80	112.00
EE - per mm	0.07	0.07	0.09	0.09	0.16	0.16

Bimba ISO 643I, VDMA 24562 Air Cylinders

Basic Cylinder (mm)

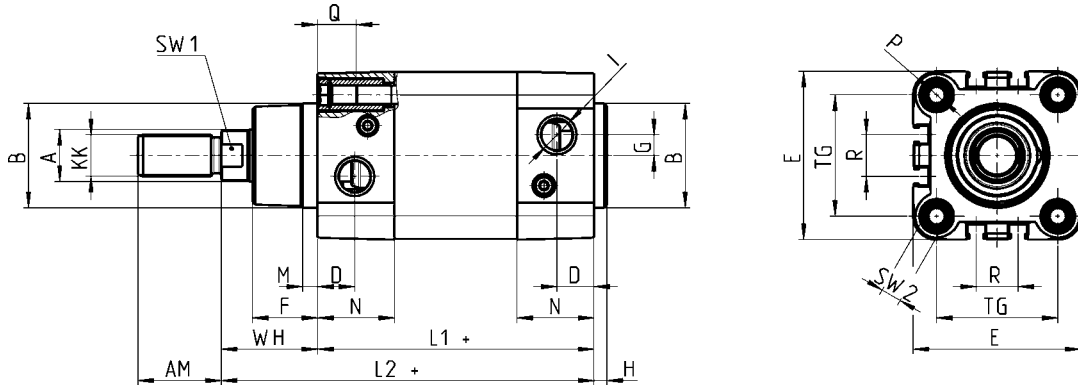

Bore	A	KK	B ^{d11}	D	F	AM	H	I	WH	L1	L2	M	N	Q	P	G	TG	R	E	SW1	SW2	Cushion Stroke	Weight (Kg)	Weight per mm
32	12	M10x1.25	30	14	18	22	4	G1/8	26	94	120	5	26	16	M6	5	32,5	13	46	10	6	19	.60	.003
40	16	M12x1.25	35	15	21	24	4	G1/4	30	105	135	5	29	16	M6	5	38	13,5	55	13	6	22	.89	.005
50	20	M16x1.5	40	15	25	32	4	G1/4	37	106	143	6	29,5	16	M8	8	46,5	16	64,5	17	8	22	1.44	.006
63	20	M16x1.5	45	21	26	32	4	G3/8	37	121	158	6	36,5	16	M8	8	56,5	28	75	17	8	22	2.08	.008
80	25	M20x1.5	45	21	30	40	4	G3/8	46	128	174	7	36	19	M10	8	72	30	93	22	10	25	3.43	.01
100	25	M20x1.5	55	23	35	40	4	G1/2	51	138	189	7	38,5	19,5	M10	8	89	40	110	22	10	25	4.85	.01

Double Rod End (mm)

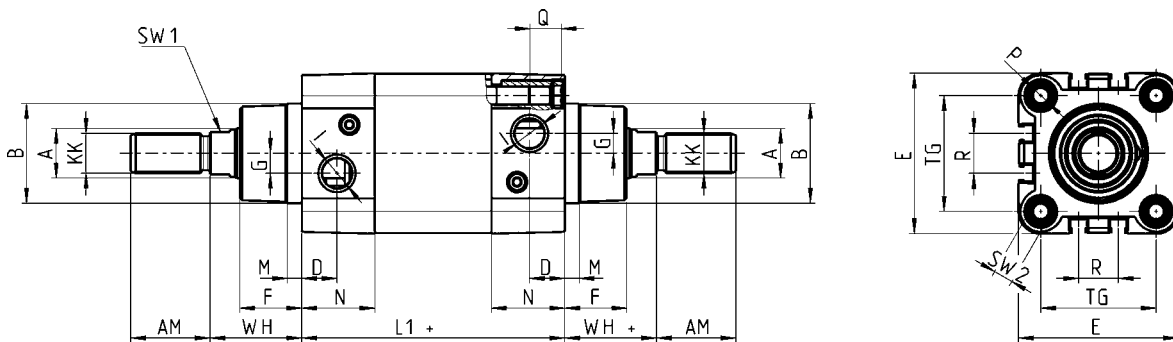

Bore	A	KK	B ^{d11}	D	F	AM	I	WH	L1	M	N	P	Q	G	TG	R	E	SW1	SW2	Cushion Stroke	Weight (Kg)	Weight per mm
32	12	M10x1.25	30	14	18	22	G1/8	26	94	5	26	M6	16	5	32,5	13	46	10	6	19	.69	.003
40	16	M12x1.25	35	15	21	24	G1/4	30	105	5	29	M6	16	5	38	13,5	55	13	6	22	1.06	.006
50	20	M16x1.5	40	15	25	32	G1/4	37	106	6	29,5	M8	16	8	46,5	16	64,5	17	8	22	1.76	.008
63	20	M16x1.5	45	21	26	32	G3/8	37	121	6	36,5	M8	16	8	56,5	28	75	17	8	22	2.40	.01
80	25	M20x1.5	45	21	30	40	G3/8	46	128	7	36	M10	19	8	72	30	93	22	10	25	4.06	.01
100	25	M20x1.5	55	23	35	40	G1/2	51	138	7	38,5	M10	19,5	8	89	40	110	22	10	25	5.55	.01

Bimba ISO 6431, VDMA 24562 Air Cylinders

Foot Bracket (mm)

MS1 - □

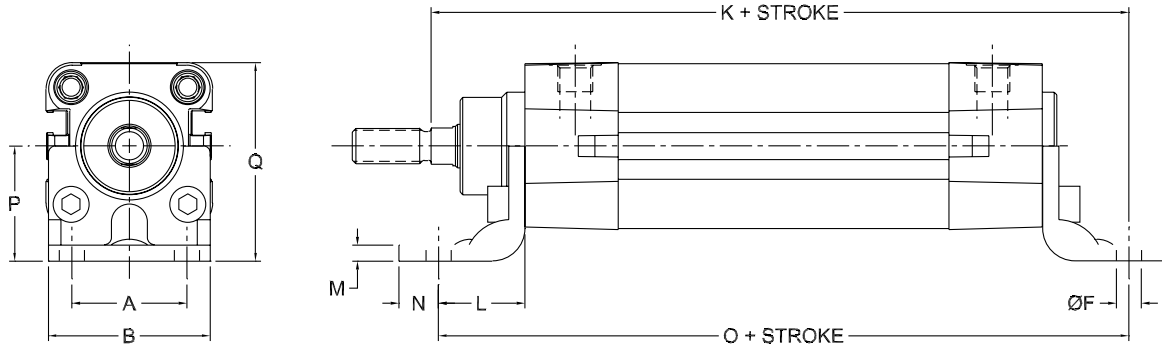

Model	K	L	M	N	O	P	Q	Weight (Kg)
MS1-32	144	24	4.5	11	142	32	55	.156
MS1-40	163	28	4.5	8	161	36	64	.186
MS1-50	175	32	5.5	15	170	45	77	.388
MS1-63	190	32	5.5	13	185	50	88	.438
MS1-80	215	41	6.5	14	210	63	110	.846
MS1-100	230	41	6.5	15	220	128	126	1.085



Front and Rear Flange (mm)

MF - □

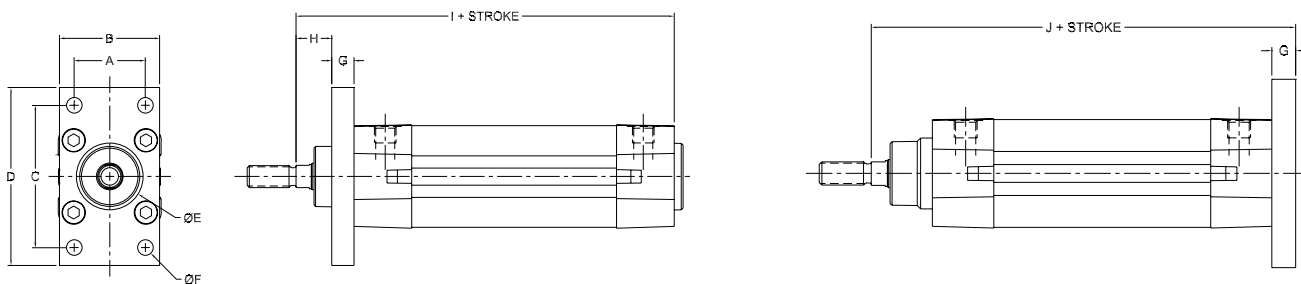

Model	A	B	C	D	E	F	G	H	I	J	Weight (Kg)
MF-32	32	45	64	80	Ø30	Ø7	10	16	120	130	.218
MF-40	36	52	72	90	Ø35	Ø9	10	20	135	145	.270
MF-50	45	65	90	110	Ø40	Ø9	12	25	143	155	.522
MF-63	50	75	100	120	Ø45	Ø9	12	25	158	170	.667
MF-80	63	95	126	150	Ø45	Ø12	16	30	174	190	1.505
MF-100	75	115	150	170	Ø55	Ø14	16	35	189	205	2.500

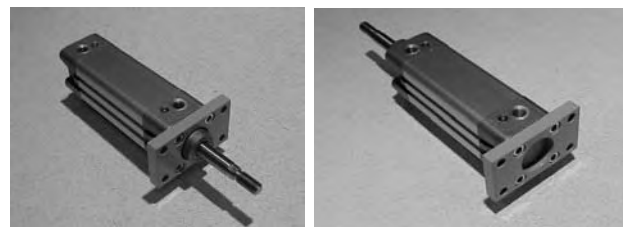

ISO 6431, VDMA
24562 Air Cylinders

ISO 6431
Accessories

ISO 6432/ETOP
Cylinders

ISO 6432
Accessories

PCE Air Cylinders

PCE Accessories

Bimba ISO 643I, VDMA 24562 Air Cylinders

Clevis Mount (mm)

MP2 - □

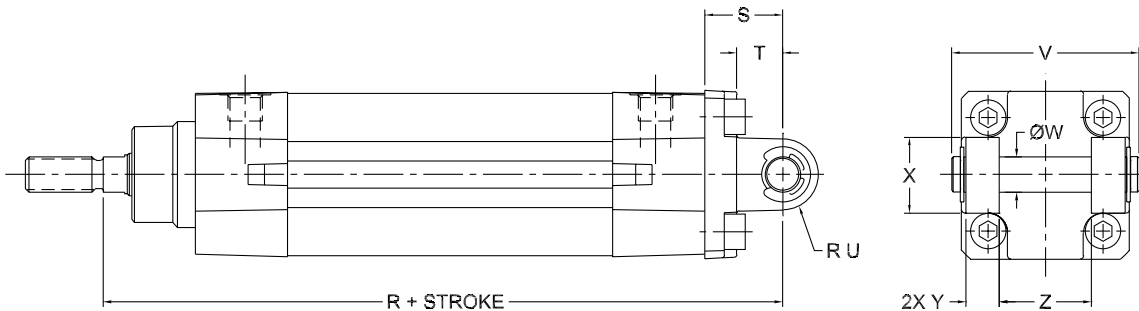

Model	R	S	T	U	V	W	X	Y	Z	Weight (Kg)
MP2-32	142	22	12	R10	53	Ø10	22	9.5	26	.111
MP2-40	160	25	15	R12	60	Ø12	26	12	28	.157
MP2-50	170	27	15	R12	68	Ø12	28	14	32	.234
MP2-63	190	32	20	R16	79	Ø16	39	15	40	.376
MP2-80	210	36	21	R16	99	Ø16	46	20	50	.639
MP2-100	230	41	26	R20	121	Ø20	55	25	60	1.008



Pivot Mount (mm)

MP4 - □

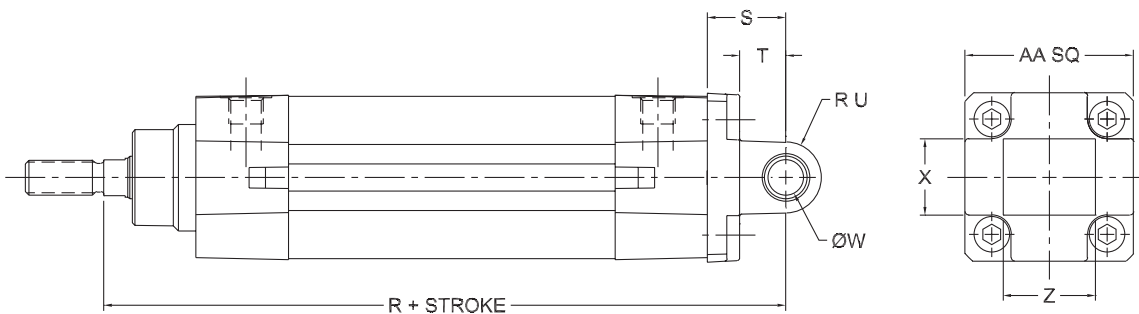

Model	R	S	T	U	W	X	Z	AA	Weight (Kg)
MP4-32	142	22	12	R10	Ø10	22	26	48	.081
MP4-40	160	25	15	R12	Ø12	26	28	54	.108
MP4-50	170	27	15	R12	Ø12	28	32	66	.174
MP4-63	190	32	20	R16	Ø16	39	40	76	.257
MP4-80	210	36	21	R16	Ø16	46	50	95	.483
MP4-100	230	41	26	R20	Ø20	55	60	114	.690



Bimba ISO 6431, VDMA 24562 Air Cylinders

Accessories (mm)

Pivot Bracket - Type 2

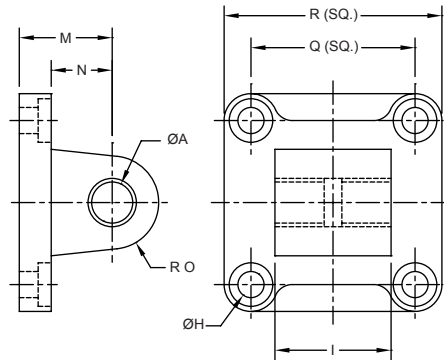

Model	A	H	I	M	N	O	Q	R	Weight (Kg)
PB2-32	Ø10	Ø6.6	26	22	13	R10	32.5	45	.054
PB2-40	Ø12	Ø6.6	28	25	16	R12	38	52	.076
PB2-50	Ø12	Ø9	32	27	16	R12	46.5	65	.123
PB2-63	Ø16	Ø9	40	32	21	R16	56.5	75	.212
PB2-80	Ø16	Ø11	50	36	22	R16	72	95	.420
PB2-100	Ø20	Ø11	60	41	27	R20	89	115	.667

Pivot Bracket - Type 1

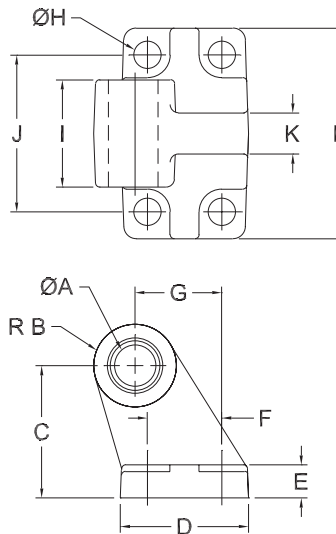

Model	A	B	C	D	E	F	G	H	I	J	K	L	Weight (Kg)
PB1-32	Ø10	R10	32	31	8	18	21	Ø6.6	26	38	10	51	.058
PB1-40	Ø12	R11	36	35	10	22	24	Ø6.6	28	41	15	54	.141
PB1-50	Ø12	R13	45	45	12	30	33	Ø9	32	50	16	65	.144
PB1-63	Ø16	R15	50	50	14	35	37	Ø9	40	52	16	67	.203
PB1-80	Ø16	R15	63	60	14	40	47	Ø11	50	66	20	86	.314
PB1-100	Ø20	R19	71	70	17	50	55	Ø11	60	76	20	96	.658

ISO 6431, VDMA
24562 Air Cylinders

ISO 6431
Accessories

ISO 6432/ETOP
Cylinders

ISO 6432
Accessories

PCE Air Cylinders

PCE Accessories

Bimba ISO 643I, VDMA 24562 Air Cylinders

Accessories

Clevis Bracket

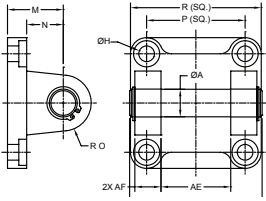

Model	A	H	M	N	O	P	R	AD	AE	AF	Weight (Kg)
CB-32	Ø10	Ø6.6	22	13	R10	32.5	45	52	26	9.5	.086
CB-40	Ø12	Ø6.6	25	16	R12	38	52	59	28	12	.132
CB-50	Ø12	Ø9	27	16	R12	46.5	65	67	32	14	.186
CB-63	Ø16	Ø9	32	21	R16	56.5	75	77	40	15	.322
CB-80	Ø16	Ø11	36	22	R16	72	95	97	50	20	.543
CB-100	Ø20	Ø11	41	27	R20	89	115	121	60	25	.922

Pivot Pin

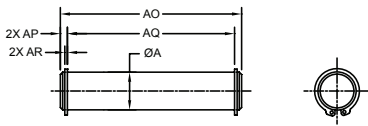

Model	A	AO	AP	AQ	AR	Weight (Kg)
PP-32	Ø10	52	3	46	1.1	.035
PP-40	Ø12	59	3	53	1.1	.055
PP-50	Ø12	67	3	61	1.1	.060
PP-63	Ø16	77	3	71	1.1	.127
PP-80	Ø16	97	3	91	1.1	.160
PP-100	Ø20	121	5	111	1.3	.300

Rod Clevis

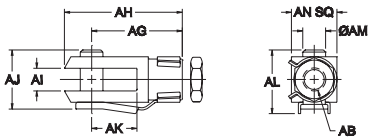

Bore	Model	AB	AG	AH	AI	AJ	AK	AL	AM	AN	Weight (Kg)
32	RC-M10x1.25	M10x1.25	40	52	10	26	20	28	10	20	.097
40	RC-M12x1.25	M12x1.25	48	62	12	32	24	34	12	24	.157
50, 63	RC-M16x1.5	M16x1.5	64	83	16	40	32	42	16	32	.356
80, 100	RC-M20x1.5	M20x1.5	80	105	20	48	40	50	20	40	.714

Spherical Rod Eye

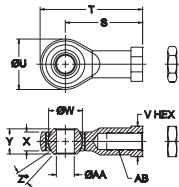

Bore	Model	S	T	U	V	W	X	Y	Z	AA	AB	Weight (Kg)
32	SRE-M10x1.25	43	57	Ø28	17	Ø19	10.5	14	13°	Ø10	M10x1.25	.080
40	SRE-M12x1.25	50	66	Ø32	19	Ø22	12	16	13°	Ø12	M12x1.25	.124
50, 63	SRE-M16x1.5	64	85	Ø42	23	Ø28.5	15	21	15°	Ø16	M16x1.5	.248
80, 100	SRE-M20x1.5	77	102	Ø50	30	Ø35	18	25	14°	Ø20	M20x1.5	.438

Rod Nut

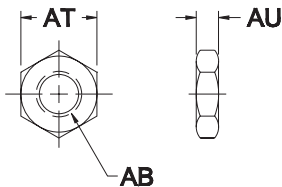

Bore	Model	AB	AT	AU	Weight (Kg)
32	RN-4	M10x1.25	17	5	.006
40	MN-1	M12x1.25	19	7	.010
50, 63	MN-2	M16x1.5	24	8	.017
80, 100	MN-5	M20x1.5	30	9	.030

Rod Coupler

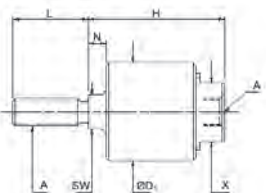

Bore	Model	A	B	D ₁	H	L	N	SW	X
25, 32	AC-M10x1.25	M10x1.25	5	29	40	24	5.3	10	17
40	AC-M12x1.25	M12x1.25	7	32	47	24	8.2	13	20
50, 63	AC-M16x1.5	M16x1.5	8	32	48	32	10	13.5	20
80, 100	AC-M20x1.5	M20x1.5	9	45	57	40	10	21	28

Bimba ISO 6431, VDMA 24562 Air Cylinders

Accessories

Prices

Mounting Kits and Accessories	32mm	40mm	50mm	63mm	80mm	100mm
MS1 Bore (Foot Bracket Kit)	\$19.95	\$21.80	\$25.70	\$28.55	\$33.45	\$46.55
MF Bore (Flange Kit)	22.30	26.20	29.45	36.15	45.65	51.50
MP2 Bore (Pivot Female Kit)	25.55	25.85	28.55	31.55	38.05	47.50
MP4 Bore (Pivot Male Kit)	20.45	20.95	23.40	25.85	32.10	38.05
PB1 Bore (Pivot Bracket)	19.60	19.95	21.90	24.25	29.45	35.45
PB2 Bore (Pivot Bracket)	19.60	19.95	21.90	24.25	29.45	35.45
CB Bore (Clevis Bracket)	24.50	24.90	26.95	29.75	35.45	44.85

Rod Accessories

Rod Clevis	List
RC-M10x1.25	\$ 7.95
RC-M12x1.25	11.90
RC-M16x1.5	21.25
RC-M20x1.5	43.90

Spherical Rod Eyes	List
SRE-M10x1.25	\$28.70
SRE-M12x1.25	33.30
SRE-M16x1.5	63.85
SRE-M20x1.5	98.50

Rod Nuts	List
RN-4	\$ 1.00
MN-1	1.50
MN-2	2.15
MN-5	4.70

Rod Alignment Couplers	List
AC-M10x1.25	\$36.35
AC-M12x1.25	41.75
AC-M16x1.5	75.75
AC-M20x1.5	92.20

Pivot Pins	List
PP-32	\$ 7.95
PP-40	8.60
PP-50	8.80
PP-63	10.00
PP-80	10.80
PP-100	15.55

Switches	List
MRS-AB	\$23.15
MRS-ABQ	35.05
HSC-AB	35.05
HSC-ABQ	46.10
HSK-AB	35.05
HSK-ABQ	46.10

ISO 6431, VDMA
24562 Air Cylinders

ISO 6431
Accessories

ISO 6432/CE/TP
Cylinders

ISO 6432
Accessories

PCE Air Cylinders

PCE Accessories

Bimba ISO 6432 Air Cylinders

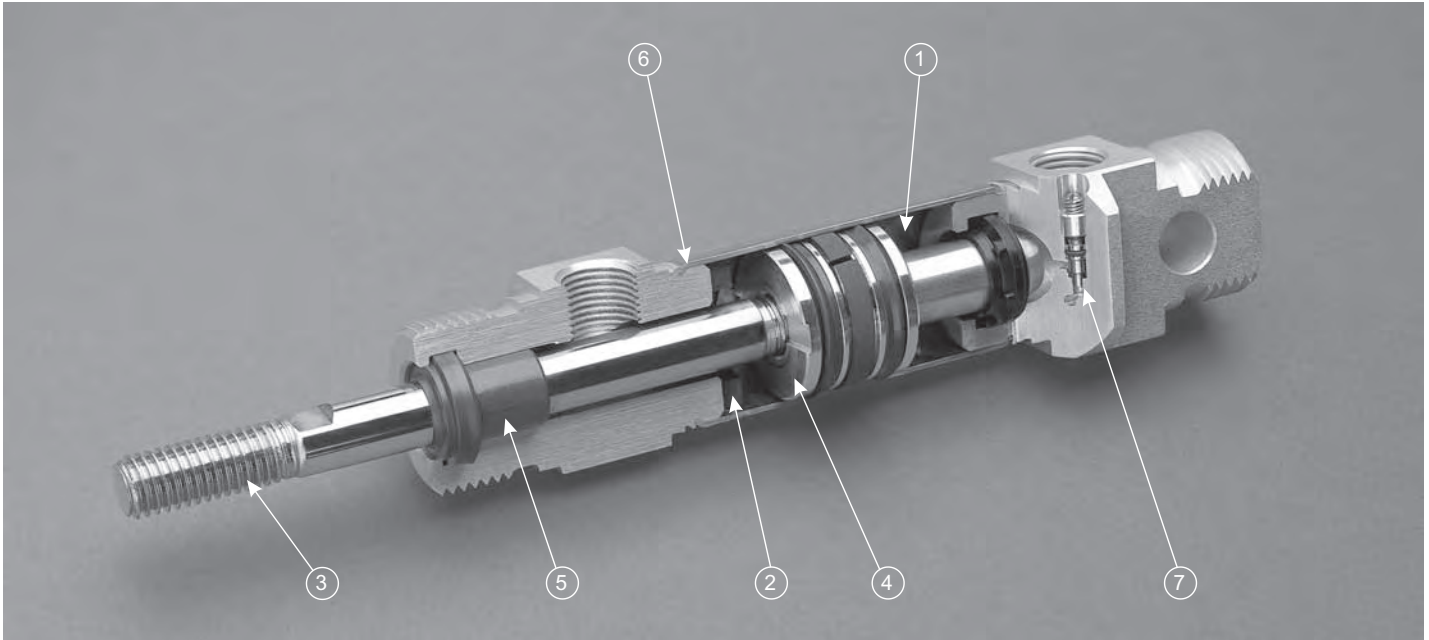

BIMBA meets YOUR NEEDS

- **Reliable Service, World-Wide**
 - From a world-wide leader producing millions of actuators each year
- **Environmental**
 - Pre-lubricated for longer, maintenance free operation ①
- **Noise Reduction**
 - Shock absorbing bumpers ②
- **Performance And Quality Processes Throughout**
 - Roll formed threads ③
 - High strength pistons permanently riveted and sealed ④
 - Roller burnished stainless steel rods
- **Productivity**
 - Advanced bearing and seal materials for higher speed applications ⑤
- **Safety**
 - Double rolled construction ⑥
 - Permanent mechanical retention; needles cannot blow out under pressure ⑦
- **Reduced Envelope**
 - Space savings available resulting from smaller external dimensions
- **A Material For Any Application**
 - Heads available in Aluminum, Stainless Steel and Delrin®
- **Unique Customer Solutions**
 - Rapid design and delivery time for custom modifications

Bimba ISO 6432 Air Cylinders

How to Order

The Model Number for all Bimba ISO 6432 Cylinders consists of five Alphanumeric clusters. The first designates the *Type*, the second the *Bore Size*, the third the *Stroke Length*, the fourth the *Mounting* style, and the fifth the *Options*.

Please refer to the chart below for an explanation of the following model number:

EM-25-100-N-CNT: This is an ISO 6432 Type Cylinder with a magnet, with 25mm Bore Size, 100mm Stroke Size, Nose Mounted, and with Cushions in Both Heads and No Thread Rod.

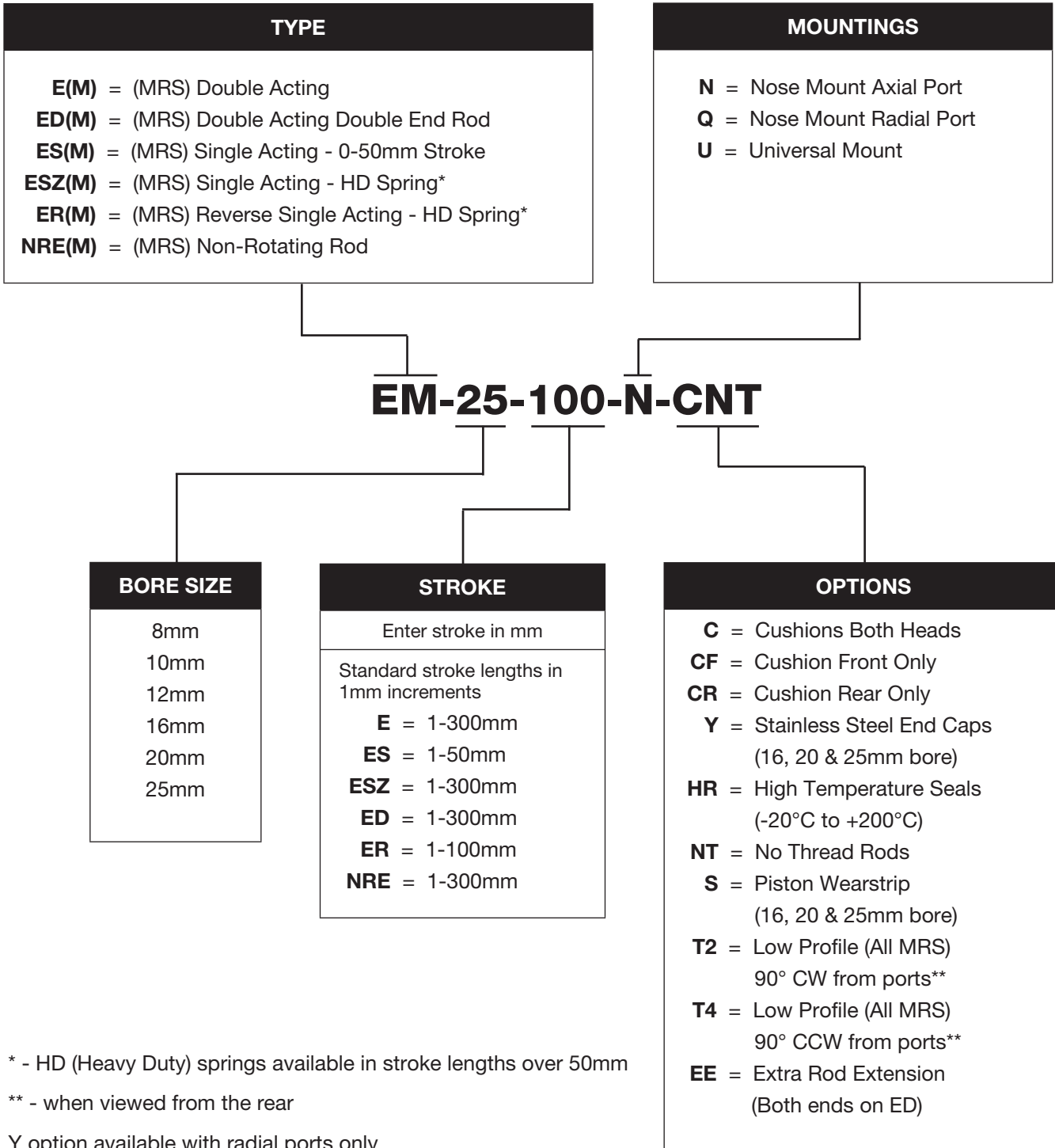

* - HD (Heavy Duty) springs available in stroke lengths over 50mm

** - when viewed from the rear

Y option available with radial ports only

ISO 6431, VDMA
24562 Air Cylinders

ISO 6431
Accessories

ISO 6432/CE/TP
Cylinders

ISO 6432
Accessories

PCE Air Cylinders

PCE Accessories

Bimba ISO 6432 Air Cylinders

List Prices

E - Bore - Stroke - Mount - Options

	8mm	10mm	12mm	16mm	20mm	25mm
Nose Mount Base (-N)	\$22.35	\$24.50	\$26.95	\$28.70	\$30.60	\$32.15
Universal Base (-U)	24.15	26.75	29.00	30.80	32.70	34.65
Stroke	.09	.09	.10	.10	.10	.10
EEX.XX (per mm)	.06	.06	.07	.07	.07	.07
HR (High Temperature Seals)	11.15	11.55	12.00	12.45	14.00	14.50
Cushions Per End	n/a	n/a	n/a	10.25	10.25	10.25
S (Wear Strip)	n/a	n/a	n/a	2.45	3.10	3.70
Y (SS End Caps)	n/a	n/a	n/a	66.95	73.65	80.30
M (Magnet Prefix)	n/a	12.15	12.15	12.15	12.15	12.15
NR (Non-rotating)	n/a	n/a	n/a	7.85	8.60	9.60
Stroke Adder for NR	n/a	n/a	n/a	.11	.11	.11
EEX.XX (per mm) for NR	n/a	n/a	n/a	.08	.08	.08
T (Switch Track)	n/a	3.10	3.10	3.10	3.10	3.10

Standard strokes are 1mm increments to 300mm. Non-standard and longer strokes, add Schedule 27.

No charge options: Q, Side Ported Rear Head (use Nose Mount base price); NT, Nontreaded Rod.

ES - Bore - Stroke - Mount - Options

	8mm	10mm	12mm	16mm	20mm	25mm
Nose Mount Base (-N)	\$18.40	\$20.05	\$21.70	\$23.85	\$25.75	\$28.70
Universal Mount Base (-U)	20.75	22.70	24.25	26.15	28.05	30.30
Stroke	.10	.10	.10	.11	.12	.13
HR (High Temperature Seals)	6.15	6.20	6.30	6.45	6.80	7.70
EEX.XX (per mm)	.06	.06	.07	.07	.07	.07
M (Magnet Prefix)	n/a	12.15	12.15	12.15	12.15	12.15
Z (Heavy Spring and long Strokes; Prefix)	n/c	n/c	n/c	n/c	n/c	n/c
T (Switch Track)	n/a	3.10	3.10	3.10	3.10	3.10

Standard strokes are 1mm increments to 50mm. For longer strokes, order as ESZ model.

No charge options: Q (use Nose Mount base price); NT

*Z option required for strokes longer than 50mm. ESZ strokes are standard in 1mm increments from 1 to 150mm. Non-standard strokes, add Schedule 27.

ED - Bore - Stroke - Options

	8mm	10mm	12mm	16mm	20mm	25mm
Base	\$31.75	\$35.05	\$35.25	\$39.15	\$40.90	\$42.20
Stroke	.12	.12	.12	.12	.12	.13
HR (High Temperature Seals)	14.80	14.95	15.40	15.75	17.75	18.35
Cushions per end	n/a	n/a	n/a	10.25	10.25	10.25
S (Wear Strip)	n/a	n/a	n/a	2.45	3.10	3.70
Y (SS End Caps)	n/a	n/a	n/a	66.95	73.65	80.30
EEX.XX (per mm)	.08	.08	.08	.08	.08	.08
M (Magnet Prefix)	n/a	12.15	12.15	12.15	12.15	12.15
T (Switch Track)	n/a	3.10	3.10	3.10	3.10	3.10

Standard strokes are 1mm increments to 300mm. Non-standard and longer strokes, add Schedule 27.

No charge options: NT

Bimba ISO 6432 Air Cylinders

List Prices

ER - Bore - Stroke - Mount - Options

	8mm	10mm	12mm	16mm	20mm	25mm
Nose Mount Base (-N)	\$21.55	\$26.50	\$27.90	\$29.80	\$31.40	\$33.05
Universal Mount Base (-U)	27.25	29.00	30.75	32.55	34.05	35.50
Stroke	.10	.10	.10	.11	.12	.13
HR (High Temperature Seals)	8.60	8.65	8.75	8.85	9.15	10.15
EEX.XX (per mm)	.06	.06	.07	.07	.07	.07
M (Magnet Prefix)	n/a	12.15	12.15	12.15	12.15	12.15
T (Switch Track)	n/a	3.10	3.10	3.10	3.10	3.10

Standard strokes are 1mm increments to 100mm. Non-standard and longer strokes, add Schedule 27.

No charge options: NT

Type PCE - Bore - Stroke - Mount - Options

	16mm	20mm	25mm
Nose Mount Base (-N)	\$45.70	\$47.15	\$48.70
Universal Mount Base (-U)	47.15	48.70	50.05
Stroke	.10	.10	.10
Cushions per end	10.25	10.25	10.25
S (Wear Strip)	2.45	3.10	3.70
EEX.XX (per mm)	.07	.07	.07
M (Magnet Prefix)	12.15	12.15	12.15
T (Switch Track)	3.10	3.10	3.10

Standard strokes are 1mm increments to 500mm. Non-standard and longer strokes, add Schedule 27.

No charge options: NT

PCED - Bore - Stroke - Mount - Options

	16mm	20mm	25mm
Nose Mount Base (-N)	\$56.30	\$57.75	\$59.25
Stroke	.12	.12	.13
Cushions per end	10.25	10.25	10.25
S (Wear Strip)	2.45	3.10	3.70
EEX.XX (per mm)	.08	.08	.08
M (Magnet Prefix)	12.15	12.15	12.15
T (Switch Track)	3.10	3.10	3.10

Standard strokes are 1mm increments to 300mm. Non-standard and longer strokes, add Schedule 27.

No charge options: NT

ISO 6432 Position Sensing Switches

Model Number	Price ¹	Model Number	Price ¹
MRS-.027-B-□	\$22.90	MRS-.027-BL-□	\$27.55
MRS-.027-XB-□	30.15	MRS-.027-XBL-□	36.40
MRS-.027-BQ-□	43.20	MRS-.027-BLQ-□	51.55
MRS-.027-BQC-□	70.00	MRS-.027-BLQC-□	78.35
MRS-.027-BQCX-□	83.40	MRS-.027-BLQCX-□	91.75

¹Price includes band

ISO 6431, VDMA
24562 Air Cylinders

ISO 6431
Accessories

ISO 6432/CE/TP
Cylinders

ISO 6432
Accessories

PCE Air Cylinders

PCE Accessories

Bimba ISO 6432 Air Cylinders

Accessories

Foot Bracket

Bore	Model Number	Price
8, 10	FB-1	\$4.50
12, 16	FB-2	5.75
20, 25	FB-3	7.70

Flange Mount

Bore	Model Number	Price
8, 10	MF-1	\$ 3.35
12, 16	MF-2	4.40
20, 25	MF-3	6.50

Clevis Foot

Bore	Model Number	Price
8, 10	CFB-1	\$ 7.55
12, 16	CFB-2	8.55
20, 25	CFB-3	10.50

Rod Clevis

Bore	Model Number	Price
8, 10	RC-M4X0.7	\$ 4.30
12, 16	RC-M6X1.0	5.40
20	RC-M8X1.25	6.60
25	RC-M10X1.25	7.95

Mounting Nut

Bore	Model Number	Price
8, 10	MN-1	\$ 1.50
12, 16	MN-2	2.15
20, 25	MN-3	4.65

Rod Nut

Bore	Model Number	Price
8, 10	RN-1	\$ 0.75
12, 16	RN-2	0.75
20	RN-3	0.95
25	RN-4	1.00

Metric Quik-Flo® Flow Controls

Spherical Rod Eyes

Bore	Model Number	Price
8, 10	SRE-M4X0.7	\$16.40
12, 16	SRE-M6X1.0	17.05
20	SRE-M8X1.25	17.60
25	SRE-M10X1.25	28.70

Knurled Knob

Model Number	Price
FCPM-1-Q4-L	\$21.90
FCPM-1-Q6-L	21.90
FCPM-2-Q4-L	22.70
FCPM-2-Q6-L	22.85
FCPM-2-Q8-L	23.15
FCPM-4-Q6-L	29.70
FCPM-4-Q8-L	30.10

Recessed Needle

Model Number	Price
FCPM-1-Q4-R	\$18.70
FCPM-1-Q6-R	18.70
FCPM-2-Q4-R	22.70
FCPM-2-Q6-R	22.85
FCPM-2-Q8-R	23.15
FCPM-4-Q6-R	29.70
FCPM-4-Q8-R	30.10

PCE Accessories (All Stainless Construction)

Foot Bracket

Bore	Model Number	Price
16	FB-2-SS	\$12.10
20, 25	FB-3-SS	14.05

Clevis Foot (Pivot Bracket)

Bore	Model Number	Price
16	CFB-2-SS	\$18.85
20, 25	CFB-3-SS	19.70

Rod Clevis

Bore	Model Number	Price
16	RC-2-SS	\$22.60
20	RC-3-SS	24.90
25	RC-4-SS	27.15

Mounting Nut

Bore	Model Number	Price
16	MN-2-SS	\$ 2.40
20, 25	MN-3-SS	3.20

Rod Nut

Bore	Model Number	Price
16	RN-2-SS	\$ 1.05
20	RN-3-SS	1.50
25	RN-4-SS	2.10

Bimba ISO 6432 Air Cylinders

Compatibility Chart

Due to design or incompatibility restrictions, the following options may **NOT** be ordered in combination. For example stainless steel end cap may not be ordered with cushions.

Options NT and EE are available independently, with each other or with all viable option combinations.

BORE	OPTION				
	NRE	C	Y	M	S
8	N/A	N/A	N/A	N/A	N/A
10	N/A	N/A	N/A	N/A	N/A
12	N/A	N/A	N/A	N/A	N/A
16	C, Y	NRE, Y	NRE, C	S	M
20	C, Y	NRE, Y	NRE, C	S	M
25	C, Y	NRE, Y	NRE, C	S	M

Conversion Tables

	Metric Unit Of Measure	Metric To Imperial Conversion	Imperial Unit Of Measure	Imperial To Metric Conversion
Force	Newtons (N)	x 0.2248	Pounds (lbs)	x 4.448
Pressure	Bar (b)	x 14.5	Pounds Per Square Inch (PSI)	x 0.069
Measurement	Millimetres	x 0.03937	Inches	x 25.4
Temperature	Centigrade	$\frac{9 \times ^\circ C + 32}{5}$	Fahrenheit	$\frac{5 \times (^{\circ} F - 32)}{9}$

General Specifications

	BORE					
	8	10	12	16	20	25
Cushion Length (mm) Each End	N/A			18	21	21
Operating Pressure Range	10 bar					
Maximum	0.5 bar					
Minimum - Double Acting						
Operating Temperature Range	-10°C to +80°C					
Standard Seals	-20°C to +200°C					
High Temperature Seals						
Operating Media	Filtered Compressed Air/Lubricated or Non-Lubricated					
Standard Stroke Lengths	See Table on page 11.11					
Maximum Stroke Length*	1000mm					
Stroke Tolerance	+1.0mm/-0mm					
Piston Speed	5mm/s to 1000mm/s (Higher speed available on request)					
Life Expectancy	3000km					

* Varies according to bore size, please consult your local BIMBA distributor.

ISO 6431, VDMA
24562 Air Cylinders

ISO 6431
Accessories

ISO 6432/CE/TP
Cylinders

ISO 6432
Accessories

PCE Air Cylinders

PCE Accessories

Bimba ISO 6432 Air Cylinders

Weights

	BORE					
	8	10	12	16	20	25
Option N	20	22	41	53	102	149
Option U	23	25	46	59	118	167
Type ED	28	30	61	74	152	218
adder per 10mm stroke	2	2	4	5	8	11

Weights (approximate) are for zero stroke, in grams.

Rod Buckling Formula

The maximum recommended cylinder stroke is dependent upon:

1. Mounting type
2. Rod diameter
3. Rod end connection

Using the following formula it is possible to determine the buckling load for a given stroke length of cylinder

$$BL = \frac{\pi^2 EJ}{(l \times M)^2 S}$$

BL = Permissible Buckling Load (N)
 E = Young's Modulus of Elasticity (N/mm²)
 J = Moment of Inertia (mm⁴)
 l = Buckling Length = Stroke (mm)
 M = Stroke Multiplier (see table below)
 S = Safety Factor (recommended minimum 5)

HOW TO CALCULATE ROD BUCKLING FORCES

EXAMPLE:

Q. What is the buckling load for a 25mm bore cylinder with a pivoted and guided load attached, stroke 200mm?

A. Using the formula: $BL = \frac{\pi^2 EJ}{(l \times M)^2 S}$

$$E = 190.05 \times 10^3 \text{ N/mm}^2$$

$$l = 200 \text{ mm (stroke)}$$

$$M = 2 \text{ (for pivoted and guided load)}$$

$$S = 5 \text{ (safety factor)}$$

$$D = 10 \text{ mm (piston rod diameter for cylinder)}$$

$$J = \frac{\pi D^4}{64} = \frac{\pi 10^4}{64} = 490.87 \text{ mm}^4$$

$$BL = \frac{\pi^2 \times 190.05 \times 10^3 \times 490.9}{(2 \times 200)^2 \times 5} = 1150.9 \text{ N} - 1.15 \text{ kN}$$

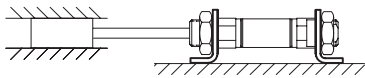
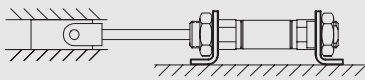
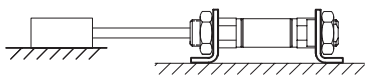
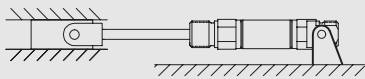
ROD END CONNECTION	CYLINDER MOUNTING	TYPE	STROKE MULTIPLIER
FIXED & GUIDED		A	0.5
PIVOTED & GUIDED		B	0.7
FIXED & SUPPORTED		C	2
PIVOTED & GUIDED		C	2

Bimba ISO 6432 Air Cylinders

Output Forces

Cylinder output forces can be determined in one of two ways:

1. Calculation

$$\text{Cylinder Output Force (N)} = \text{Power Factor} \times \text{Pressure (bar)}$$

BORE	POWER FACTOR	
	EXTENSION	RETRACTION
8	5.3	4.0
10	7.9	6.6
12	11.3	8.5
16	20.1	17.3
20	31.4	26.1
25	49.1	41.2

2. Graph

Extend

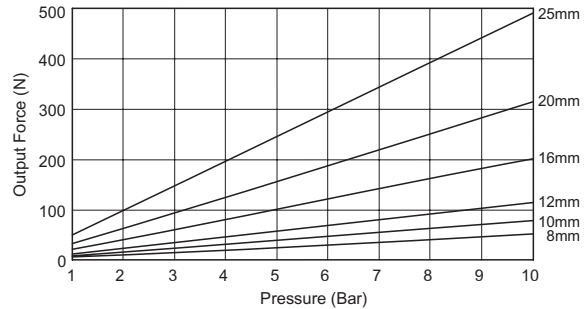

Retract

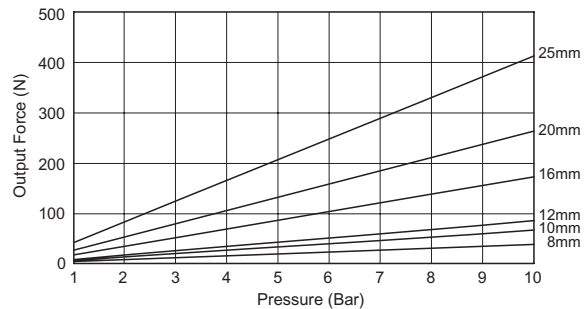

Air Consumption Chart

The Air Consumption Chart is based on the following formula for a complete cylinder cycle (cylinder extends and retracts):

$$Q = \left[\frac{\pi D^2}{4} + \left(\frac{\pi(D^2 - d^2)}{4} \right) \right] hp 10^{-6}$$

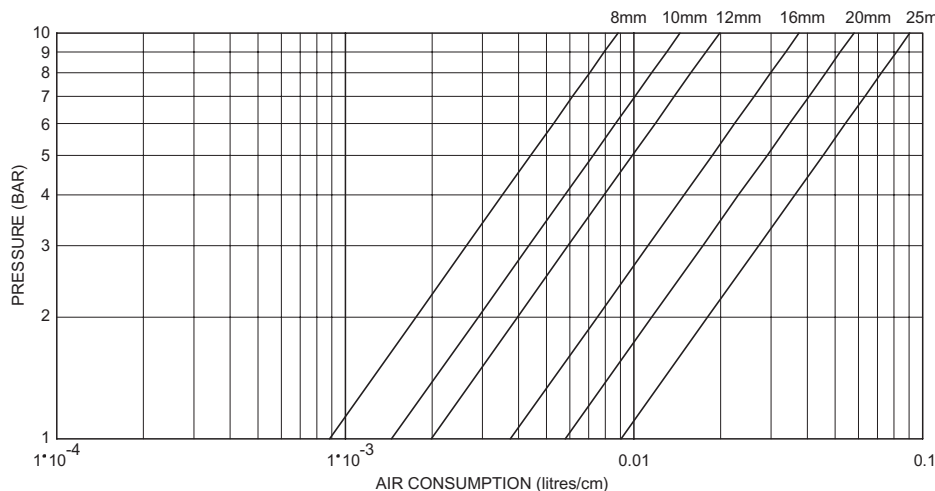

Draw a line across for the pressure used. Where this intersects the required bore size, draw a vertical line down. This will give you the air consumption. Multiply this by the stroke in cm, and this will give the air consumption per cycle.

Q = Air volume per cm of stroke (L)
 D = Piston or piston rod diameter (mm)
 h = Stroke (mm)
 p = Operating pressure (bar)
 d = Piston rod diameter (mm)

EXAMPLE:

Cylinder Stroke = 2.5cm
 Cylinder Bore = Ø25mm
 Operating Pressure = 7 Bar
 Air Consumption = 0.158 Litres

Bimba ISO 6432 Air Cylinders

Materials

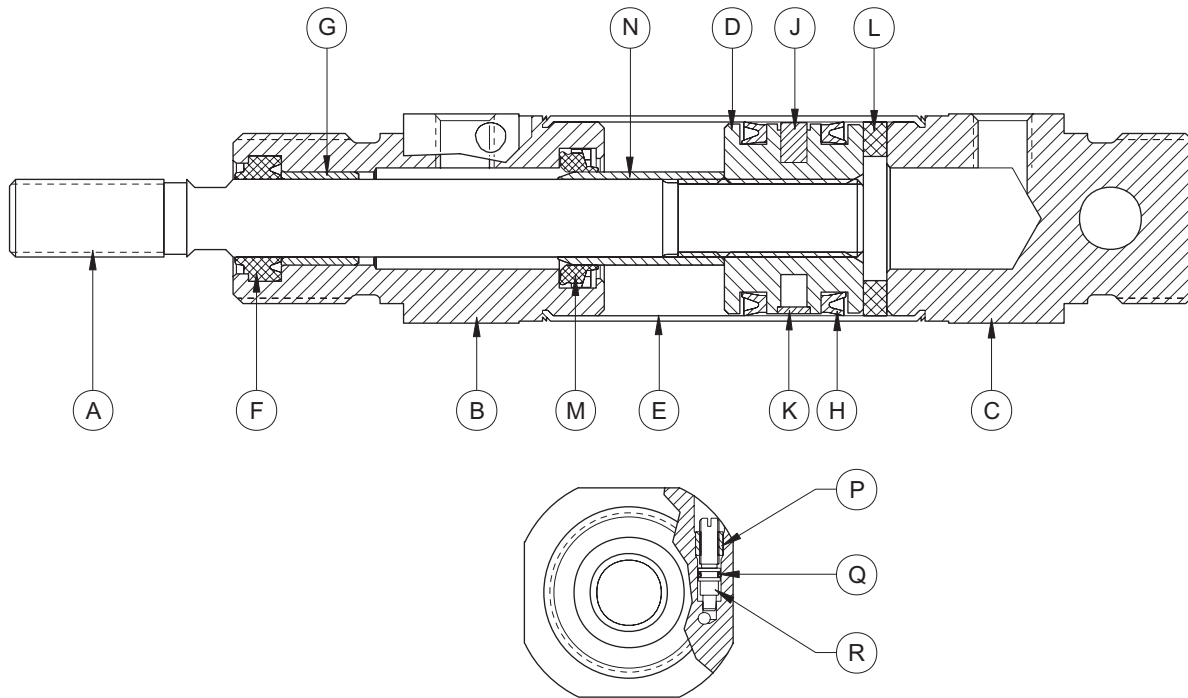

ITEM	COMPONENT	MATERIAL
A	Piston Rod	Stainless Steel (type 303 s31)
B	Rod Guide	Aluminium Alloy (anodized) Delrin® Plastic - (type PCE) Stainless Steel - (option Y)
C	Rear Head	Aluminium Alloy (anodized) Delrin® Plastic - (type PCE) Stainless Steel - (option Y)
D	Piston	Aluminium Alloy Brass - (type ED)
E	Body	Stainless Steel (type 304)
F	Rod Seal/Rod Wiper	Nitrile (NBR) or Fluoro-rubber (FPM) - (option HR)
G	Rod Bearing	Self Lubricating Thermoplastic Alloy
H	Piston Seal	Nitrile (NBR) or Fluoro-rubber (FPM) - (option HR)
J	Magnet	Neodymium Iron Boron Nitrile
K	Piston Bearing Ring	Carbon Filled PTFE
L	Bumper	Fluoro-rubber (FPM)
M	Cushion Seal	Nitrile (NBR) - Standard or Fluoro-rubber (FPM) - (option HR)
N	Cushion Sleeve	Aluminium Alloy
P	Cushion Screw Retainer	Aluminium Alloy (anodized) Stainless Steel - (type PCE)
Q	Cushion o-ring	Fluoro-rubber (FPM)
R	Cushion Screw	Stainless Steel (type 303 s31)

Bimba ISO 6432 Air Cylinders

Double Acting

NOSE MOUNT - N option

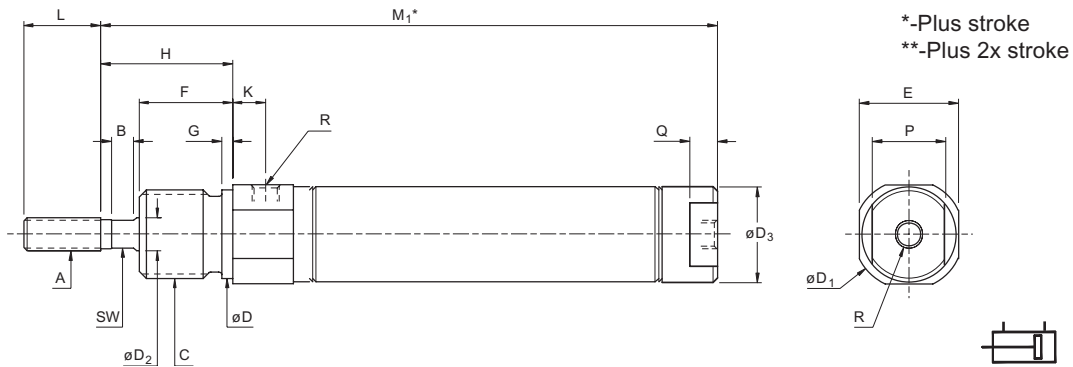

UNIVERSAL MOUNT - U option

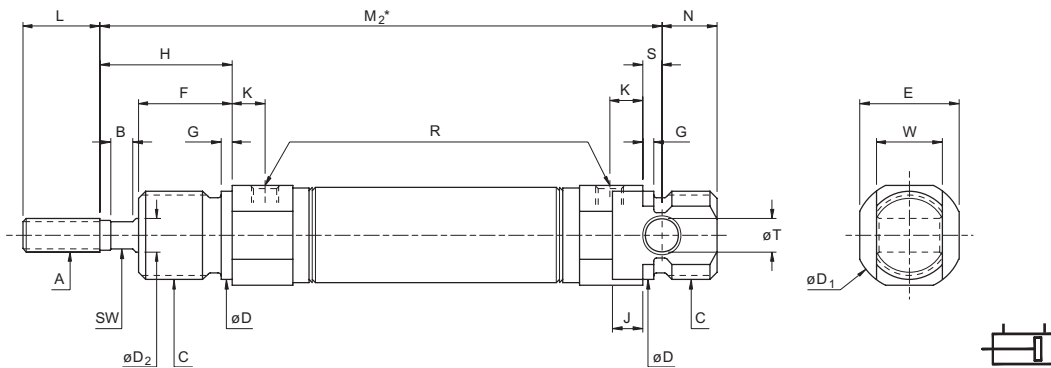

DOUBLE ENDED

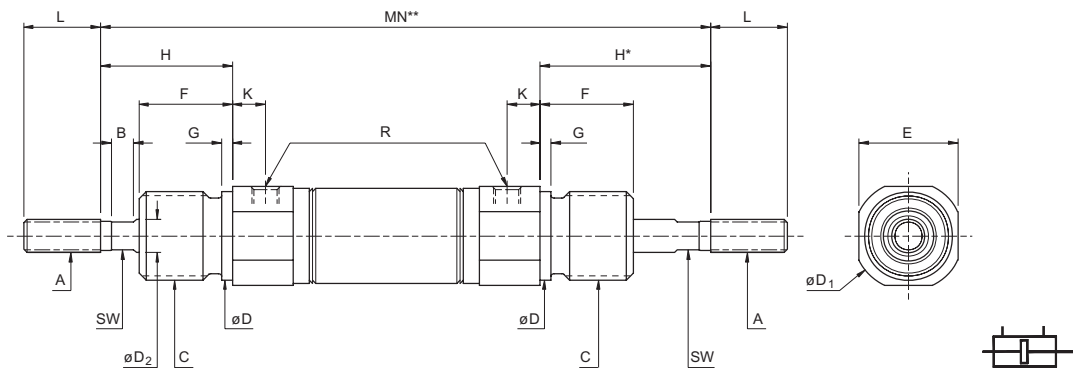

Bore	A ^{9g}	B	C ^{9g}	D	D ₁	D ₂ ^{h8}	D ₃	E	F	G	H	J	K	L	P	Q	N	R	S	T ^{H9}	W ^{H13}	SW	M ₁	M ₂	MN
8	M4x0.7	-	M12x1.25	12	17	4	9	15	12	2	16	3	6	12	8	4	9	M5x0.8	3	4	8	-	56.5	64	77
10	M4x0.7	-	M12x1.25	12	17	4	11	15	12	2	16	3	6	12	10	5	9	M5x0.8	3	4	8	-	58	64	77
12	M6x1.0	4	M16x1.5	16	20	6	13	18	17	2	24	5.4	6	14	10	5	8	M5x0.8	3.6	6	12	5	68.7	77	97
16	M6x1.0	4	M16x1.5	16	20	6	17	18	17	2	24	5.5	6	14	13	5	10	M5x0.8	3.5	6	12	5	74	84	104
20	M8x1.25	4	M22x1.5	22	28	8	21	24	19	3	25	8	8	19	19	7	11	G1/8	4	8	16	6	84.5	96	117
25	M10x1.25	4	M22x1.5	22	30	10	26	27	22	3	30	6	8	20	22	8	11	G1/8	6	8	16	8	92	106	130

ISO 6431, VDMA
24562 Air Cylinders

ISO 6431
Accessories

ISO 6432/CE/TP
Cylinders

ISO 6432
Accessories

PCE Air Cylinders

PCE Accessories

Bimba ISO 6432 Air Cylinders

Q option

Radially ported rear head available on non-cushioned cylinders.
The M_1 dimension increases by the amount shown alongside

Bore	Adder	Bore	Adder
8	4.5	16	6.5
10	3	20	7.5
12	4.7	25	8

Double Acting - With Adjustable Cushioning

NOSE MOUNT - N option

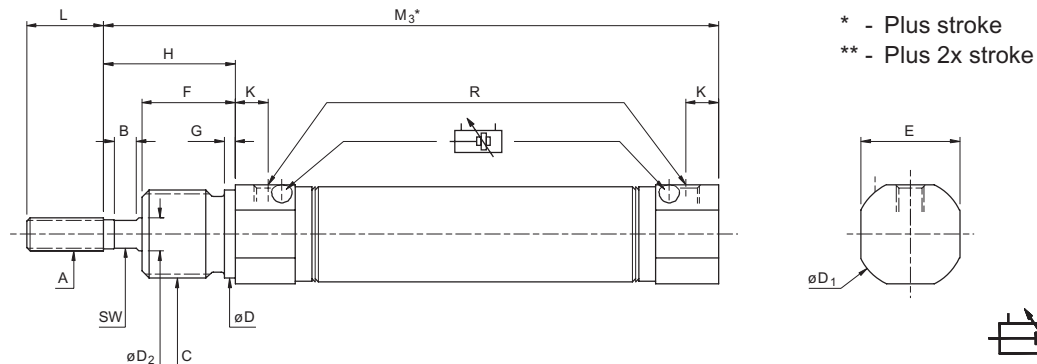

UNIVERSAL MOUNT - U option

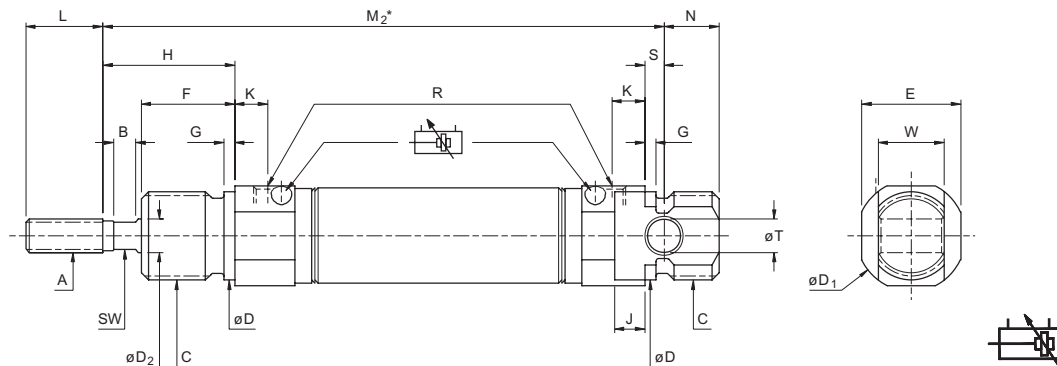

DOUBLE ENDED

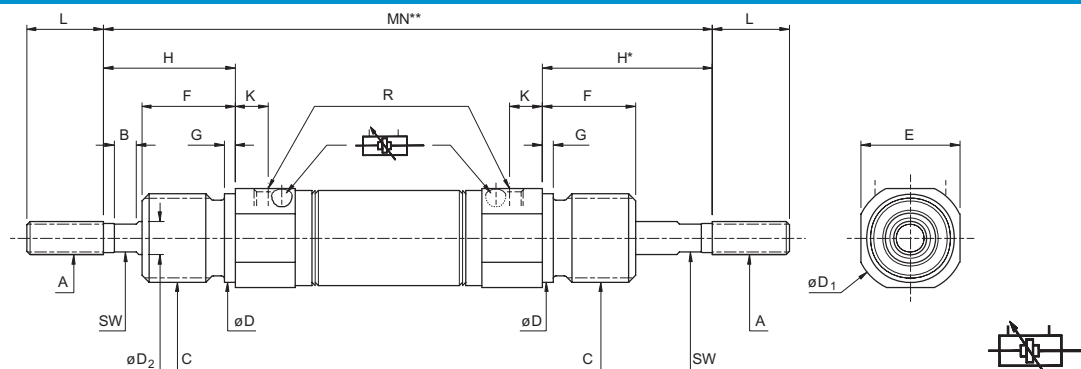

Bore	A ⁶⁹	B	C ⁶⁹	D	D ₁	D ₂ ^{h8}	E	F	G	H	J	K	L	N	R	S	T ^{h9}	W ^{d13}	SW	M ₂	M ₃	MN
16	M6x1.0	4	M16x1.5	16	20	6	18	17	2	24	5.5	6	14	10	M5x0.8	3.5	6	12	5	84	80.5	104
20	M8x1.25	4	M22x1.5	22	28	8	24	19	3	25	8	8	19	11	G1/8	4	8	16	6	96	92	117
25	M10x1.25	4	M22x1.5	22	30	10	27	22	3	30	6	8	20	11	G1/8	6	8	16	8	106	100	130

Bimba ISO 6432 Air Cylinders

Single Acting - Spring To Retract (ESZ)

The ESZ & ER series offer a heavier spring force than the ES, and the flexibility of strokes exceeding 50mm.

NOSE MOUNT - N option

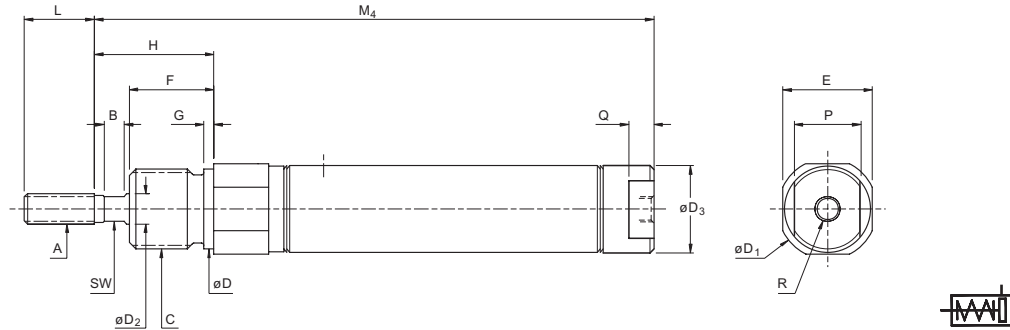

UNIVERSAL MOUNT - U option

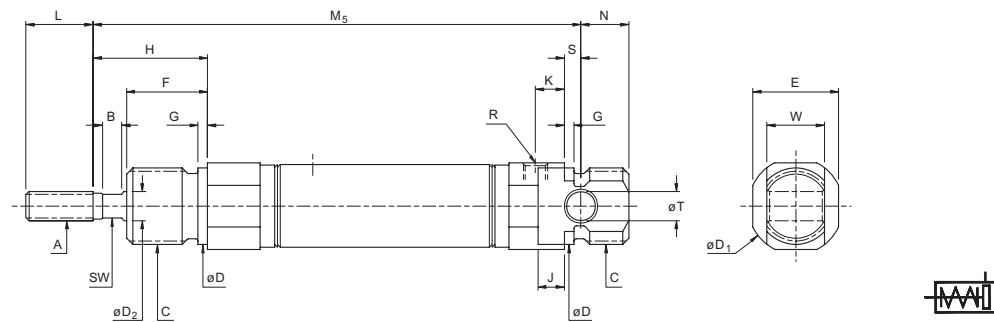

Single Acting - Spring To Extend (ER)

NOSE MOUNT - N option

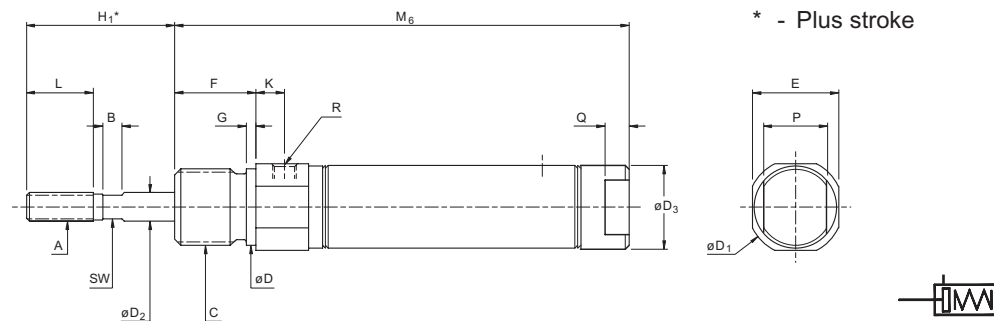

UNIVERSAL MOUNT - U option

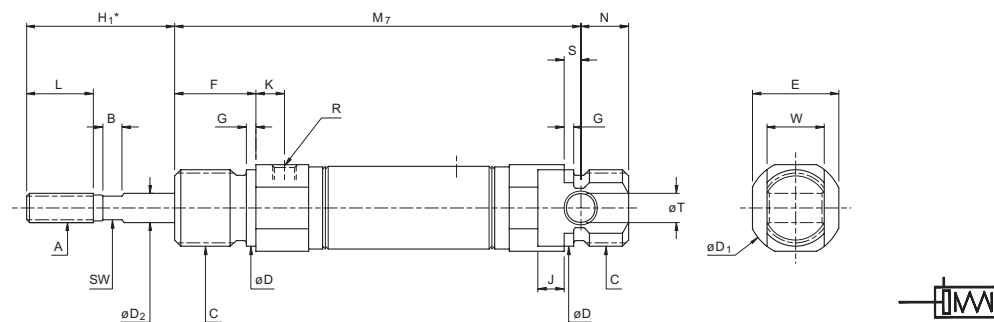

See following page for dimensional tables

Bimba ISO 6432 Air Cylinders

Bore	A ^{6g}	B	C ^{6g}	D	D ₁	D ₂ ^{h8}	D ₃	E	F	G	H	H ₁	J	K	L	N	P	Q	R	S	T ^{h9}	W ^{d13}	SW
8	M4x0.7	-	M12x1.25	12	17	4	9	15	12	2	16	16	3	6	12	9	8	4	M5x0.8	3	4	8	-
10	M4x0.7	-	M12x1.25	12	17	4	11	15	12	2	16	16	3	6	12	9	10	5	M5x0.8	3	4	8	-
12	M6x1.0	4	M16x1.5	16	20	6	13	18	17	2	24	21	5.4	6	14	8	10	5	M5x0.8	3.6	6	12	5
16	M6x1.0	4	M16x1.5	16	20	6	17	18	17	2	24	21	5.5	6	14	10	13	5	M5x0.8	3.5	6	12	5
20	M8x1.25	4	M22x1.5	22	28	8	21	24	19	3	25	27	8	8	19	11	19	7	G1/8	4	8	16	6
25	M10x1.25	4	M22x1.5	22	30	10	26	27	22	3	30	28	6	8	20	11	22	8	G1/8	6	8	16	8

Calculating Cylinder Lengths

In order to provide greater customer flexibility, Bimba ESZ and ER cylinders can be fitted with multiple springs. To calculate the length ("M" dimension), use the following formula based on the table below:

Example 1: **ESZ-25-78-U**

ESZ-25-_-U Base length (M_b) = 103mm
 Multiplier = Stroke ÷ Increment = $78 \div 25 = 3.12$
 Multiplier = 3 (always round down)
 Multiplier x Adder = $3 \times 47 = 141$ mm
 Add Base Length = $141 + 103 = 244$

Add whole stroke increment:
 Stroke - (Multiplier x 25) = $78 - 75 = 3$

ESZ-25-78-U = $244 + 3 = 247$

Example 2: **ER-12-86-N**

ER-12-86-N Base length (M_b) = 60.2mm
 Multiplier = Stroke ÷ Increment = $86 \div 12.5 = 6.88$
 Multiplier = 6 (always round up)
 Multiplier x Adder = $6 \times 29 = 174$ mm
 Add Base Length = $174 + 60.2 = 234.2$

Add whole stroke increment:
 Stroke - (Multiplier x 12.5) = $86 - 75 = 11$

ER-12-86-N = $234.2 - 11 = 223.2$

	ESZ - Single Acting, Rod To Retract				ER - Single Acting, Rod To Extend			
	M ₄ (N)	M ₅ (U)	Adder	Increment	M ₆ (N)	M ₇ (U)	Adder	Increment
8	63.8	71.3	20.8	12.5	51.5	59	20.8	12.5
10	57	63	24		53	59	29	
12	67.2	75.5	26.5		60.2	68.5	29	
16	72	82	48.5	25	65	75	49	25
20	81.5	93	46.5		75.5	87	49	
25	89	103	47		81	95	41.7	

Spring Forces

Bore	ES (available up to 50mm stroke)			ESZ & ER		
	Preload At Strokes (N)			Final Load (N)	Preload At 10mm Stroke (N)	Final Load (N)
	10mm	25mm	50mm			
8	5.1	4.2	2.6	5.7	1.8	8
10	5.1	4.2	2.6	5.7	3.1	8
12	5.8	4.4	3.1	6.2	4.9	16
16	5.8	4.4	3.1	6.2	8.9	22.7
20	20	16.5	11.1	22	12	31.7
25	28	23.1	15.6	31.1	12	39.2

Bimba ISO 6432 Air Cylinders

Accessories - Carbon Steel

CLEVIS FOOT

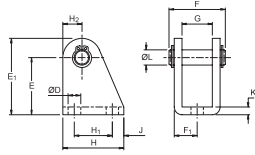

Bore	Type	D	E	E ₁	F	F ₁	G	H	H ₁	H ₂	J	K	L
8, 10	CFB-1	4.5	24	29	17	6.5	8.1	20	12.5	5	4	2.5	4
12, 16	CFB-2	5.5	27	34	23	9	12.1	25	15	7	5	3	6
20, 25	CFB-3	6.6	30	40	29.5	12	16.1	32	20	10	6	4	8

FOOT MOUNTING

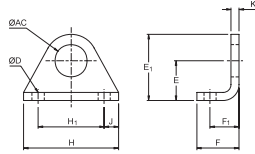

Bore	Type	AC	D	E	E ₁	F	F ₁	H	H ₁	J	K
8, 10	FB-1	12.1	4.6	15	25	16	11	36	25	5.5	3
12, 16	FB-2	16.1	5.6	20	33	20	14	45	32	6.5	4
20, 25	FB-3	22.1	6.6	25	40	24	17	56	40	8	4.5

ROD CLEVIS

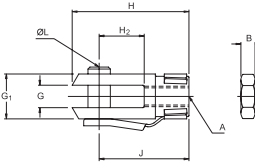

Bore	Type	A	B	G	G ₁	H	H ₂	J	L
8, 10	RC-M4x0.7	M4x0.7	3.2	4	8	21	8	16	84
12, 16	RC-M6x1.0	M6x1.0	5	6	12	31	12	24	6
20	RC-M8x1.25	M8x1.25	4	8	16	42	16	32	8
25	RC-M10x1.25	M10x1.25	5	10	20	52	24	40	10

FLANGE MOUNTING

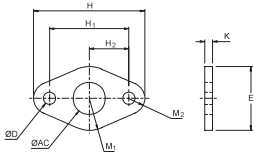

Bore	Type	AC	D	E	H	H ₁	H ₂	K	M ₁	M ₂
8, 10	MF-1	12.1	4.6	24	42	30	15	3	12	6
12, 16	MF-2	16.1	5.6	28	54	40	20	4	14	7
20, 25	MF-3	22.1	6.6	38	66	50	25	4.5	19	8

SPHERICAL ROD EYE

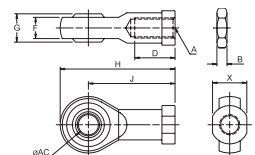

Bore	Type	A	AC	B	D	F	G	H	J	X
8, 10	SRE-M4x0.7	M4x0.7	5	3.2	10	6	8	36	27	9
12, 16	SRE-M6x1.0	M6x1.0	6	5	12	6.75	9	40	30	11
20	SRE-M8x1.25	M8x1.25	8	4	16	9	12	48	36	14
25	SRE-M10x1.25	M10x1.25	10	5	20	10.5	14	57	43	17

ROD/MOUNTING NUT

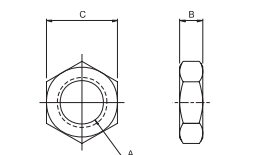

Bore	Type	A	B	C	Type	A	B	C
8, 10	RN-1	M4x0.7	3.2	7	MN-1	M12x1.25	7	19
12, 16	RN-2	M6x1.0	5	10	MN-2	M16x1.5	8	24
20	RN-3	M8x1.25	4	13	MN-3	M22x1.5	10	32
25	RN-4	M10x1.25	5	17				

ROD COUPLER

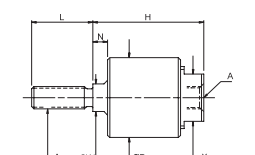

Bore	Type	A	D ₁	H	L	N	SW	X
8, 10	AC-M4x0.7	M4x0.7	14	24	14	64	-	11.3
12, 16	AC-M6x1.0	M6x1.0	29	44	13	10	10	17
20	AC-M8x1.25	M8x1.25	32	50	19	12	13	21
25, 32	AC-M10x1.25	M10x1.25	32	50	19	12	13	21
40	AC-M12x1.25	M12x1.25	32	50	19	12	13	21
50, 63	AC-M16x1.5	M16x1.5	32	50	32	12	14	21
80, 100	AC-M20x1.5	M20x1.5	45	58	29	12	21	29

Bimba PCE Air Cylinders

How to Order

The Model Number for all Bimba PCE Cylinders consists of five Alphanumeric clusters. The first designates the *Type*, the second the *Bore Size*, the third the *Stroke Length*, the fourth the *Mounting style*, and the fifth the *Options*.

Please refer to the chart below for an explanation of the following model number:

PCEM-25-100-N-CNT: This is a PCE Type Cylinder with a magnet, with 25mm Bore Size, 100mm Stroke Size, Nose Mounted, and with Cushions in Both Heads and no Rod Threads.

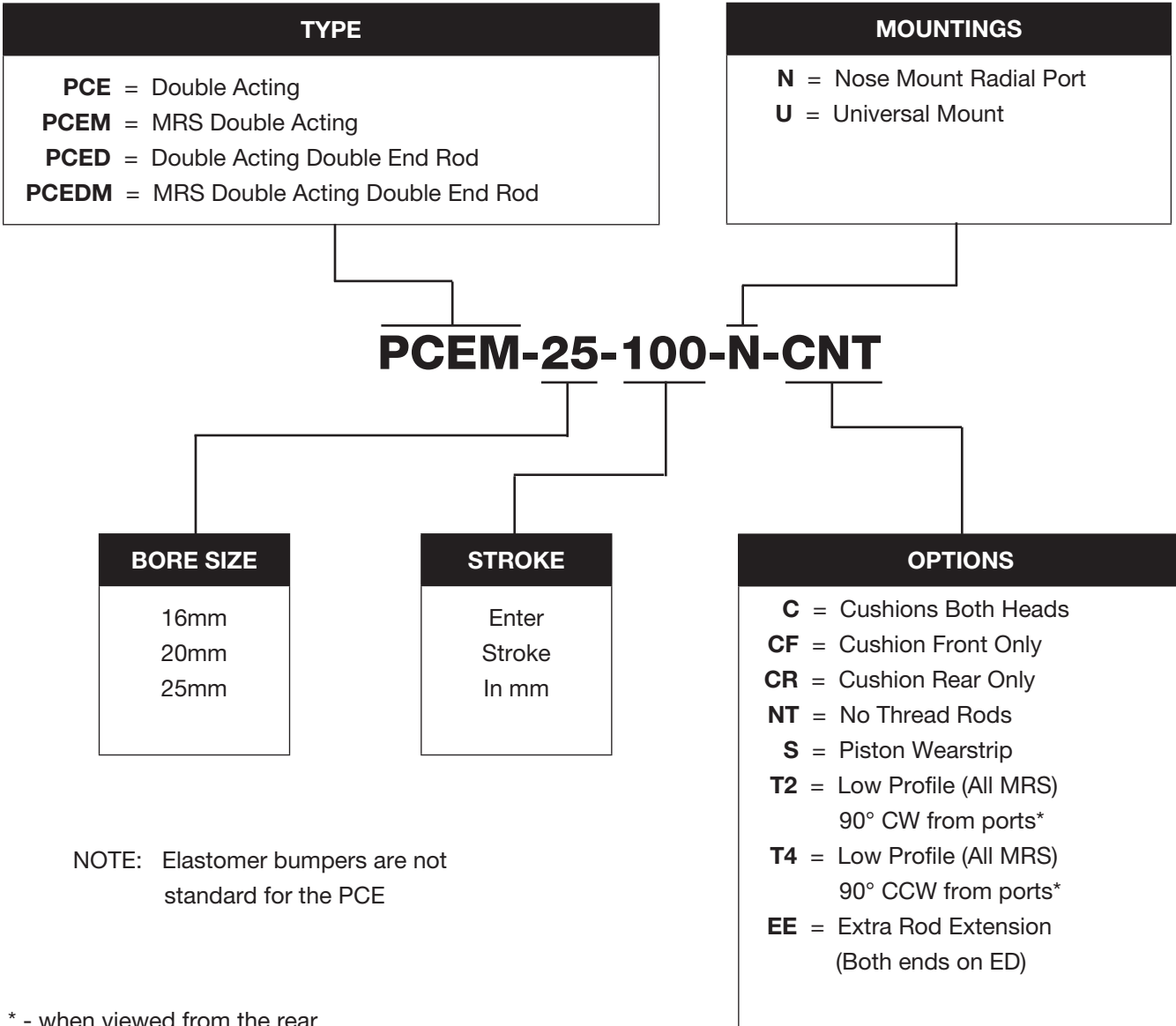

Bimba PCE Air Cylinders

General Specifications



The Bimba PCE cylinder has stainless steel body, stainless steel rod and Delrin® end caps. It is ideal for applications or operating environments that require exposure to moisture, lubricants and specific solvents.

	BORE		
	16	20	25
Cushion Length (mm) Each End	18	21	21
Head Material	Delrin® Plastic type 150SA		
Operating Pressure Max. Min.	7 bar 0.5 bar		
Operating Temperature Range	-10°C to +80°C		
Operating Media	Filtered Compressed Air/Lubricated or Non-Lubricated		
Standard Stroke Lengths	1mm to 300mm		
Maximum Stroke Length*	1000mm		
Stroke Tolerance	+1.0mm/-0mm		
Piston Speed	5mm/s to 1000mm/s		
Life Expectancy	3000km		

* Varies according to bore size, please consult your local BIMBA distributor.

Weights

	Bore		
	16	20	25
Option N	40	77	117
Option U	43	85	126
Type ED	57	116	176
adder per 10mm stroke	5	8	11

Weights (approximate) are for zero stroke, in grams.

Bimba PCE Air Cylinders

Double Acting - With Adjustable Cushioning

NOSE MOUNT - N option

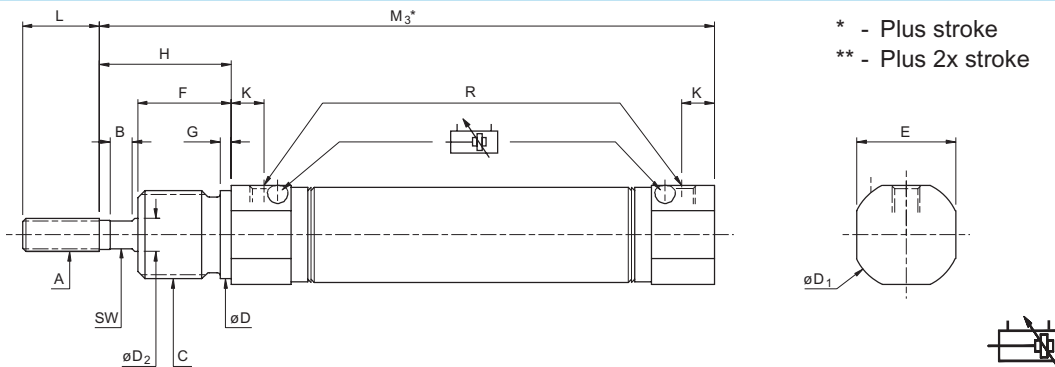

UNIVERSAL MOUNT - U option

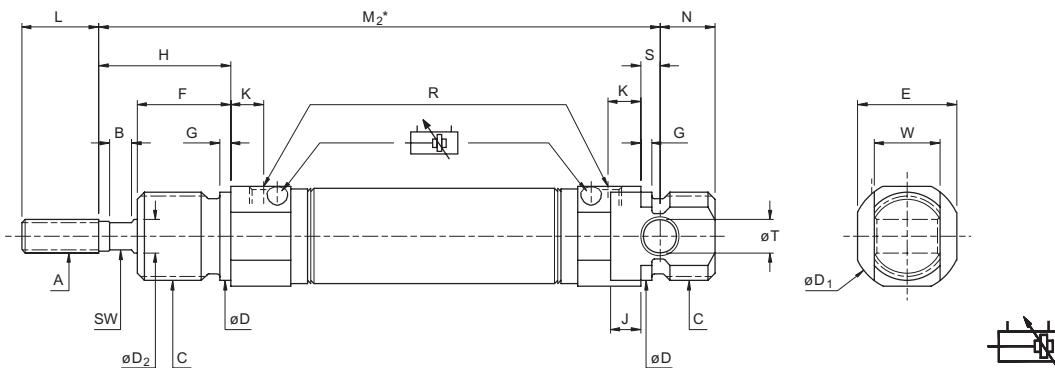

DOUBLE ENDED

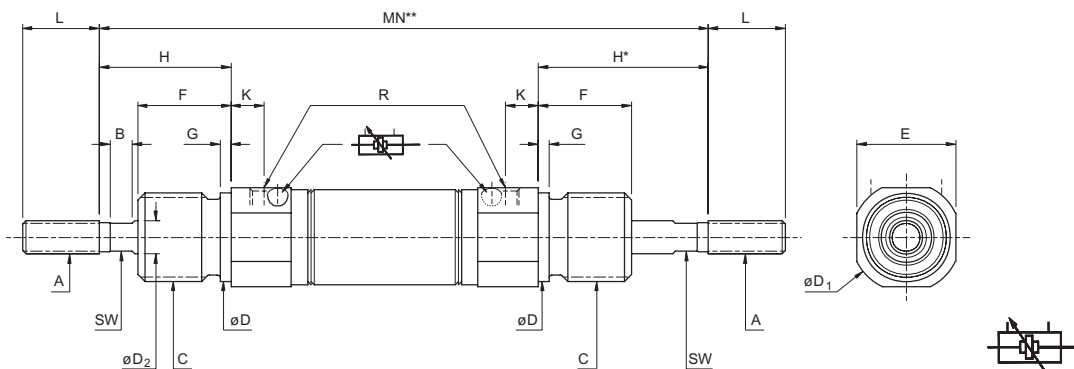

Bore	A ⁶⁹	B	C ⁶⁹	D	D ₁	D ₂ ¹⁰	E	F	G	H	J	K	L	N	R	S	T ¹⁰	W ^{d13}	SW	M ₂	M ₃	MN
16	M6x1.0	4	M16x1.5	16	20	6	18	17	2	24	5.5	6	14	10	M5x0.8	3.5	6	12	5	84	80.5	104
20	M8x1.25	4	M22x1.5	22	28	8	24	19	3	25	8	8	19	11	G1/8	4	8	16	6	96	92	117
25	M10x1.25	4	M22x1.5	22	30	10	27	22	3	30	6	8	20	11	G1/8	6	8	16	8	106	100	130

Bimba PCE Air Cylinders

Accessories - Stainless Steel

ISO 6431, DIN 18
24562 Air Cylinders

ISO 6431
Accessories

ISO 6432/ETOP
Cylinders

ISO 6432
Accessories

PCE Air Cylinders

PCE Accessories

PIVOT BRACKET

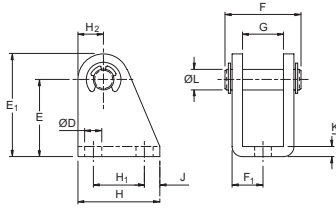

Bore	Type	D	E	E ₁	F	F ₁	G	H	H ₁	H ₂	J	K	L
16	CFB-2-SS	5.6	27	34	24	9	12.5	25	15	7	5	3	6
20, 25	CFB-3-SS	6.6	30	40	30.5	12	16.5	32	20	10	6	4	8

FOOT MOUNTING BRACKET

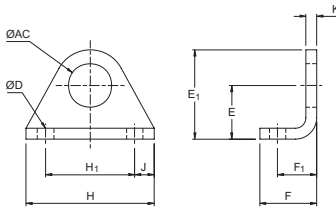

Bore	Type	AC	D	E	E ₁	F	F ₁	H	H ₁	J	K
16	FB-2-SS	16.1	5.6	20	33	20	14	42	32	5	4
20, 25	FB-3-SS	22.1	6.6	25	40	25	17	54	40	7	5

ROD CLEVIS BRACKET

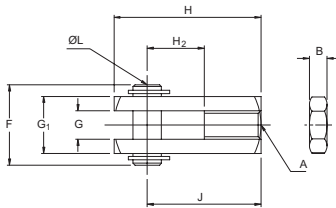

Bore	Type	A	B	F	G	G ₁	H	H ₂	J	L
16	RC-2-SS	M6x1.0	5	16	6	12	31	12	24	6
20	RC-3-SS	M8x1.25	4	20	8	16	42	16	32	8
25	RC-4-SS	M10x1.25	5	26	10	20	52	24	40	10

ROD NUT

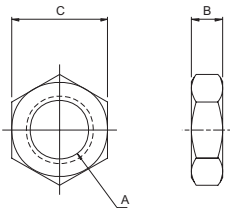

Bore	Type	A	B	C
16	RN-2-SS	M6x1.0	5	10
20	RN-3-SS	M8x1.25	4	13
25	RN-4-SS	M10x1.25	5	17

MOUNTING NUT

Bore	Type	A	B	C
16	MN-2-SS	M16x1.5	8	24
20, 25	MN-3-SS	M22x1.5	10	32